

Big Green Egg®

COMPLIMENTARY

LIFE *Style*

The Ultimate Cooking Experience®

v8.18

**The Secrets to Cooking
on the EGG:
Simplicity and Versatility**

**Exploring Mexico's
Regional Cuisine**

**Is This the Last Grill
You'll Ever Own?**

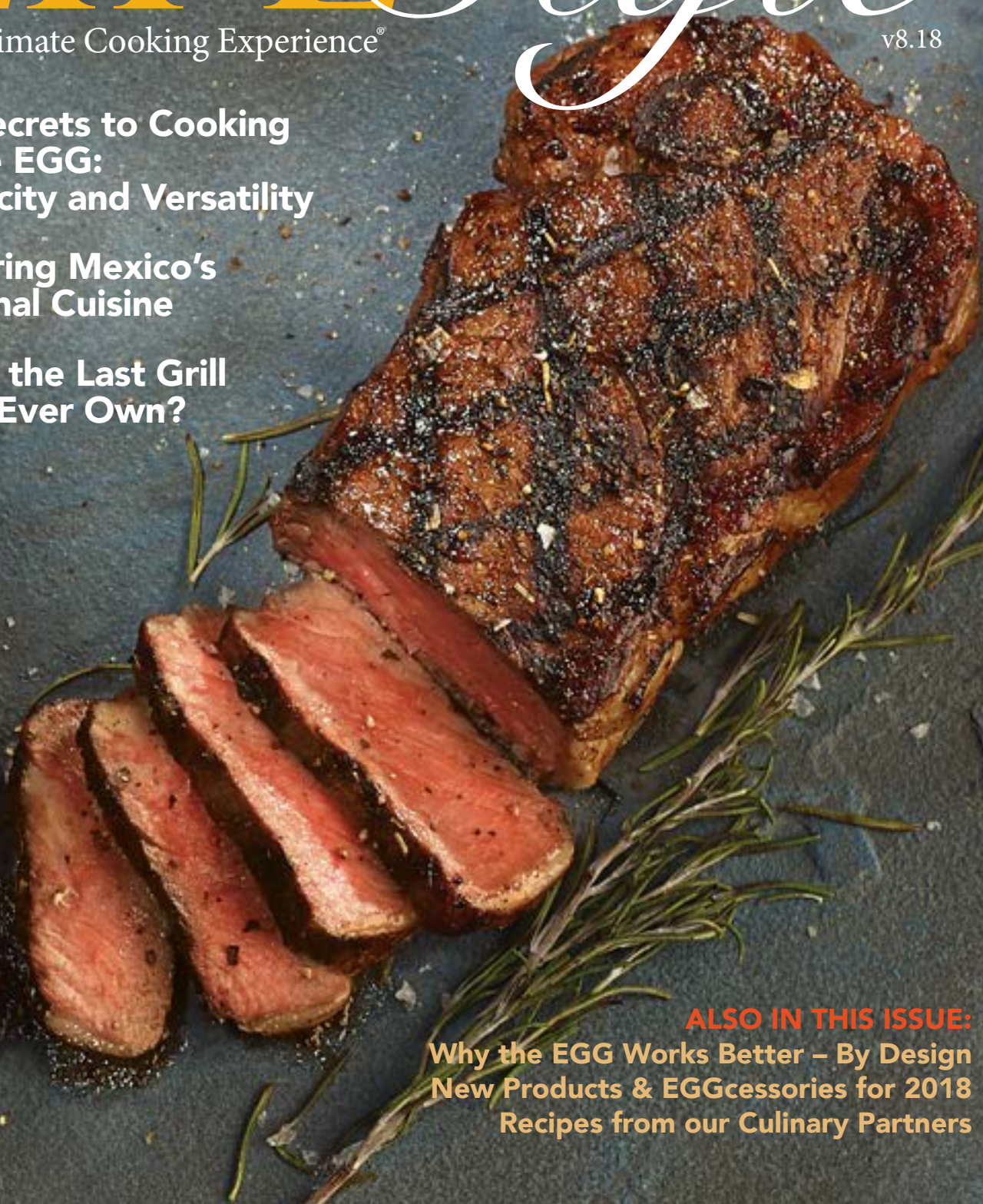

ALSO IN THIS ISSUE:
Why the EGG Works Better – By Design
New Products & EGGcessories for 2018
Recipes from our Culinary Partners



Welcome to the Culinary World of the Big Green Egg.

Years ago, I had the good fortune of enjoying a meal prepared in a traditional clay kamado and was amazed at the incredible flavor this way of cooking gave to foods. But I was not as satisfied with the low quality and inferior thermal properties of the typical kamado grill, so for over forty years our company has lovingly nurtured and enhanced our product, constantly striving to make it the very best. Along the way, we've gained a loyal following from everyday grillers to culinary aficionados and world class chefs throughout the world.

When you purchase an EGG you are getting nothing but the very best quality, and your investment in our amazing product is protected by a successful company with a reputation for manufacturing excellence. We are committed to supporting our customers with everything from lifetime warranty service to customized EGGcessories to enhance your cooking experience!

You'll soon discover that whether it's grilled, smoked, baked or roasted – everything tastes better cooked in the EGG.

Enjoy!

Ed Fisher, Founder and Chairman
Big Green Egg, Inc.

Big Green Egg LIFE Style



EGGs, EGGcessories & Cooking Tools

- 2 Your Life Will Never Taste the Same
- 4 The Big Green Egg Family
- 6 The Ultimate Cooking Experience
- 8 100% Natural Lump Charcoal
- 10 Why an EGG Works Better ... By Design
- 22 Pizza and Baking on the EGG
- 34 Big Green Egg Culinary Center
- 35 Product Catalogue
- 57 Have Questions? Ask Dr. BBQ

© 2018 by The Big Green Egg, Inc (BGE). All Rights Reserved Worldwide. Big Green Egg®, including the Big Green Egg logo and particular green color; the green grill design; EGG®; The Ultimate Cooking Experience®; Experience a World of Flavor™; convEGGtor®; MiniMaxEGG®; EGGcessories®, and others are trademarks and/or registered trademarks of BGE in the USA and other countries throughout the world. The content of this publication including all images and materials are protected by © copyright and all rights are reserved in any medium and any form of reproduction worldwide. No part of this publication may be reproduced or transmitted in any form or by any means, digital, electronic, mechanical, scanning, photocopying, recording, or otherwise without the prior written permission of BGE. Any use of these materials without the prior written consent of BGE is strictly prohibited. The BGE products, images, information or descriptions contained herein are the intellectual property of BGE and may be protected by patent, copyright or trademark. Other images and/or product names mentioned or depicted herein may be protected by copyright or trademark and are the property of their respective rights holder. Warning: The unauthorized reproduction or distribution of this copyrighted work is illegal. Criminal copyright infringement, including infringement without monetary gain, is punishable by up to five years in federal prison and a fine of \$250,000. This publication has been registered with the United States Copyright Office.



12



30



16

Experience Our World Of Flavor

- 12 Deborah Vantrece: Soul Food with a Twist
- 14 Eli Gur: Playing with Fire
- 16 Jason Lilley: Whole Lot of Smoking Going On
- 18 Andrea Bemis: Cooking with the Seasons
- 20 Wildfire on Tour: A Dream Come True
- 23 Peter Reinhart: Humble Pie
- 24 John Cox: Refined Ranch Cuisine
- 26 Lost Village Festival: EGGs in the Woods
- 28 Claudette Zepeda-Wilkins: Mexican Cuisine
- 30 Robin Wickens: New Levels of Creativity
- 32 Michele Forgione: Depth of Flavor
- 33 Big Green Egg Culinary Partners



20



26



18



SCAN HERE FOR THE RECIPE
FEATURED ON THE COVER
OR SEE PAGE 27

YOUR LIFE WILL NEVER TASTE THE SAME!

The Big Green Egg is the perfect grill for everyone ... from the world's most acclaimed chefs to the backyard chef who wants simplicity, versatility and convenience.



LOCATE
A DEALER

The Big Green Egg delivers better results – and more flavor – than all other conventional cookers combined. It's the perfect grill for everyone from the world's most acclaimed chefs to the backyard chef who wants simplicity, versatility and convenience.

GRILL

Sear steaks, chops, burgers and seafood with a flavor-packed crust unmatched by other grills. Authentic, high temperature “steak house” grilling is quick, easy and delicious!

ROAST

The Big Green Egg retains heat and moisture so well that foods just don't dry out! Poultry, lamb, beef and vegetables are naturally tastier because the juices and flavors stay locked inside for fantastic results!

LOW & SLOW

The insulating ceramics of the EGG allow for precise temperature control even at low heat. Enjoy succulent results with turkey, ham, ribs or any of your favorite cuts. Want to slow cook at low heat for fourteen to sixteen hours or longer? No problem! And an EGG is so efficient it can handle long cooks without constantly adding charcoal or checking the fire!

BAKE

The EGG bakes bread, casseroles, cakes and pies better than your kitchen oven. You'll be amazed when you bite into the most delicious slice of pizza you've ever eaten – just taste it to believe it and you'll never want to cook indoors again!

SMOKE

No smoker performs more efficiently than a Big Green Egg. You can easily add a wide variety of sumptuous flavor combinations with our natural chips and wood chunks ... each type of wood flavors meat, poultry or fish differently, giving you endless combinations to enjoy!

AMAZING RESULTS

From appetizers and entrees to desserts, the Big Green Egg will exceed all your expectations ... and with seven convenient sizes to choose from, there is a Big Green Egg to fit any lifestyle. Visit an Authorized Dealer soon to learn more about the Big Green Egg, and start writing your own culinary success story!



The Big Green Egg is a complete outdoor cooking system, delivering outstanding performance from a simple yet highly-efficient blend of

Ancient Traditions
+
Modern Technology
+
Unmatched Quality

Quite simply, it's the most technically advanced, highest quality ceramic cooker ever "hatched" – engineered to be stronger, more durable and provide better heat retention than any other outdoor cooker on the market.

But don't buy one just for the technology ... it's the fantastic cooking results that truly set the EGG apart!

This unique EGG-shaped cooker, known by its distinctive green color, leaves all ordinary kamado style cookers behind – and stands alone as the only outdoor cooker of its type ... a Big Green Egg really is The Ultimate Cooking Experience!

BigGreenEgg.com



LEARN MORE

LARGE

The Large EGG is the most popular size and a favorite to handle the cooking needs of most families and gatherings of friends.

SMALL

The Small EGG is an easy fit for patios and balconies, and often used along with a larger EGG to allow the preparation of several courses at once.



MINIMAX

Designed as the ultimate portable EGG, the MiniMax™ comes complete with its own Carrier, and will delight you with oversized results in a small package!



XXLARGE

The unrivaled XXLARGE EGG is the ultimate backyard grill, and can easily handle a family reunion or cookouts with large groups – and is perfect for restaurant and catering needs.

MEDIUM

Happiness in a more compact package – the Medium EGG is perfectly sized for smaller families and couples.



XLARGE

An XLARGE EGG accommodates cookouts with all your friends and family – and you can efficiently prepare several meals over the coals at once.



MINI

A Mini EGG is the perfect companion to larger EGGs or as a portable solution for picnics and tailgating when you want to take The Ultimate Cooking Experience with you!



THE ULTIMATE COOKING EXPERIENCE

A Big Green Egg is easy to use and as maintenance-free as it gets! With a lifetime warranty and no propane tank, burners, power cords, insulating blankets or pellet augers to worry about, the EGG is self-contained, efficient and hassle free!

Versatility is the name of the game with a Big Green Egg ... perfectly prepare anything from a steakhouse-style porterhouse to a lasagna or peach cobbler in the same grill! Tender and moist brisket, turkey and pork tenderloin, as well as vegetables, stews, stir-frys and casseroles – even pies and desserts are superb. Pizza on an EGG is simply in a class of its own! You can literally cook an entire meal – from breakfast to dinner – in an EGG!

Quick and Easy to Start

The Big Green Egg reaches cooking temperature and is ready to use in just minutes – and no need to plug it in first! Our 100% Natural Lump Charcoal is made in the USA from the very best cuts of oak and hickory hardwoods for quick lighting, superior performance and delicious results. Lighting the charcoal is simple with our natural SpeediLight starters or the EGGniter – and you'll never waste money on lighter fluid again!

Precise Temperature Control

You can grill, smoke, roast and bake at exact temperatures by easily adjusting the patented air flow systems. You have total control over temperature at your fingertips, maintaining accuracy within a few degrees! The high quality temperature gauge provides precise readings to 750°F/400°C. Many indoor ovens cannot match the accuracy of the EGG's temperature control!

Safer to Use

Because a Big Green Egg keeps the heat trapped inside, the ceramic surface doesn't get as hot as a metal grill, and the heat source is protected within a ceramic fire box inside the base.

Easy Clean Up

The Big Green Egg features an easy-to-clean professional grade stainless steel cooking grid, and the distinctive green exterior has a lifetime glaze that maintains its good looks and wipes clean easily without any need for harsh cleaners. Inside, residual heat burns away any build-up – just like a self-cleaning oven.

Patented Technology

Among many features that make the Big Green Egg by far the best outdoor cooking device are the patented components and state-of-the-art ceramic technologies that provide unrivaled thermal properties and unequaled cooking performance! The materials used in each and every EGG have performed flawlessly in extreme conditions for decades, and many EGGs are passed down to the next generation. The Big Green Egg comes with a Best-In-Class Lifetime Warranty ... it's all about uncompromising quality and performance.

BigGreenEgg.com



Know what you're buying,
and **don't settle for an
imitation** ... If it doesn't say
Big Green Egg, it isn't!

WHAT COULD BE MORE NATURAL?

**Big Green Egg
100% Premium
Oak and Hickory
Lump Charcoal ...**

**It's clean and
consistent, from
one bag to the next!**

100% Premium Oak and Hickory Lump Charcoal

Big Green Egg has long been committed to eco-friendly, organic and natural products – what else would you expect from a company whose middle name is “Green”?! When you reach for the familiar Big Green Egg bag you are getting only 100% Natural Lump Charcoal, made from American oak and hickory “ultra-premium” hardwood.

What's the difference?

Unlike some imported lump charcoal and briquettes on the market today, all-natural Big Green Egg charcoal is pure carbonized hardwood, with NO additives whatsoever. We diligently source our charcoal to make sure of that, and we ensure it contains no fillers, chemicals, treated wood or petroleum by-products of any kind either.

But more importantly, your food is simply going to taste better when you cook with our charcoal ... in fact, many chefs consider Big Green Egg charcoal one of the “secret ingredients” that contributes to the fabulous flavor of food cooked on an EGG. It's clean and consistent, from one bag to the next!

You put a lot of effort into creating your favorite recipes and meals, so don't stop short when it comes to selecting the best fuel for your EGG!

Wood Smoking Chips and Chunks

Providing a subtle ingredient to your favorite recipes, aromatic wood smoke delicately seasons food as it cooks. Because each wood imparts different flavoring to various types of meat or food, the combinations are endless. You'll have fun trying all the wood flavors – discovering which add a stronger flavor and work well with hearty cuts, and which ones are best paired with milder flavored meats, fish or vegetables.

Add amazing flavor to all of your favorite recipes!

Chips are ideal for quick bursts of smoke, while our Chunks are larger pieces of hardwood better suited for creating more smoke over a longer period of time. Big Green Egg's apple, pecan, cherry, hickory and mesquite smoking woods are well-known favorites of famous pitmasters and backyard chefs alike, and just like our signature Lump Charcoal, our Wood Chips and Chunks are sourced from only 100% natural wood, with no additives, fillers or chemicals of any kind.

Big Green Egg also offers authentic whiskey barrel smoking chips, made from the very best charred white oak barrels. When aging whiskey, the inside of each barrel is charred to caramelize the wood's natural sugars before the whiskey rests there to develop its character, flavor and aroma. Once the whiskey is bottled, we put the barrel to an even better use!





Your food is simply going to taste better when you cook with our charcoal ... in fact, many chefs consider **Big Green Egg charcoal one of the "secret ingredients"** that contributes to the fabulous flavor of food cooked on an EGG.

WHY AN EGG WORKS BETTER ... BY DESIGN

When you invest in a Big Green Egg, you are going to take home the finest, highest quality outdoor cooker ever made, offering more versatility and delivering better cooking results than anything else you've ever used! Grill, roast, smoke or bake – this one amazing vessel will do it all!



ASK DR. BBQ
ABOUT THE
BIG GREEN EGG

Why don't we offer the add-ons you often see attached to other grills? Well, the simple answer is that we've tested our own designs, as well as others, and have found no significant performance advantage.

The Product Development Team and R+D Staff at Big Green Egg are busy year-round designing, prototyping and testing just about any cooking accessory, gadget or add-on you can think of ... and when we come up with something that truly adds value to the Ultimate Cooking Experience, we release it to our Authorized Dealers and customers.

A few examples of recent innovations include the cast iron Planchas, deep dish Skillets and our new Dutch Ovens, each of which was designed in-house at Big Green Egg and has been optimized for use in an EGG with larger, easy-to-grip handles and a more robust grade of cast iron for long life and superior performance. Go ahead – just pick one up and compare it to other name brands costing much more ... you'll appreciate the quality, added benefits and lower prices – immediately!

Why no rotisserie? Here is another gadget that is just not needed because an EGG has thermal properties that are superior to other kamado-style grills, and heats more evenly because of the built-in convection effect. Simply use our Vertical Chicken or Turkey Roaster, and the heat will surround the bird while also cooking it from the inside-out for a perfect result every time, without having to plug something in to turn the poultry.

How about a hinged grid to add more charcoal while cooking? Low and slow perfectionists know that an EGG with a full load of our Natural Lump Charcoal is so efficient that it will provide a consistent heat source for 16 to 18 hours and more – without constantly opening the lid to check the charcoal or add more, which stirs up hot ash to settle on your food. So we say, why bother?

Do I need a separate pizza oven? A pizza oven attachment is another product often touted as the best addition to a grill. Maybe to a grill, but not to a Big Green Egg. You see, the EGG is already a giant convection oven and will bake pizza, calzones, flatbread and just about anything else better than the ancient brick ovens of Pompeii ever could. That's because, once again, the superior thermal properties contain and circulate the heat so evenly that foods don't dry out, and our line of pizza and baking stones – made of the same ceramics and to the same exacting standards as the EGG itself – retain heat and provide a perfectly crispy crust. If you want the best tasting pizza ever, we've got you covered!

For cooking perfection, just light your EGG, sit back and enjoy the results ... no add-ons needed!



For cooking perfection,
**just light your
EGG, sit back
and enjoy the
results ...**
no add-ons needed!

DEBORAH VANTRECE

SOUL FOOD WITH AN INTERNATIONAL TWIST



I'd been wanting an EGG for a long time and when I finally got one I put it right to work here in the restaurant kitchen. The EGG beautifully maintains temperature, something professional chefs are obsessed with.

Deborah VanTrece has lived in places as far as 6,000 miles away from her Kansas City childhood home – Israel, Spain, Switzerland, Italy, France and Argentina – learning about and loving those countries' cuisine, but she never forgot the sights and smells of restaurants smoking meat in the city legendary for barbecue.

And it wasn't just the restaurants. "In Kansas City, everybody smokes meat," says VanTrece. "My grandfather had a big pit in his back yard. He and my father taught me about barbecue. It's really in my blood. But I doubt that they could have imagined I'd be doing dishes such as cocoa-crusting lamb lollipops on a smoker."

VanTrece, chef and owner of Atlanta's Twisted Soul Cookhouse and Pours, is a long-time caterer and former owner of Edible Art Café on the east side of the city. More than 30 years of travel as an international flight attendant introduced her to the full and intense flavors of Spain, the classic dishes of France and the appeal of fresh Italian pasta. In Spain, she ate often with friends whose paella pan had to be lifted off the grill by several men. "That is real communal eating – a long table, lots of people, one giant pan, much laughter and love. Meals of good food with good people are markers in your life. You remember them vividly."

VanTrece vividly remembers the first time she ate something cooked on an EGG – a Thanksgiving turkey. "Awesome is an overused word, but that turkey was awesome. I'd been wanting an EGG for a long time and when I finally got one I put it right to work in the restaurant kitchen. The EGG beautifully maintains temperature, something professional chefs are obsessed with."

A passion for good meat is de rigueur for somebody who grew up in Kansas City, but VanTrece is also a greens fanatic. She grew up eating mustard greens as part of what she thought of as "soul food" unique to the Midwest. But when she got to Atlanta, she was surprised. "I discovered that Southerners really love greens, but that it's all about the collards."

At Twisted Soul, VanTrece uses a mixture of four greens – mustard, turnip, collard and kale – alongside the fried chicken, mac and cheese and sweet tea-marinated baby back ribs. Greens are also served with dishes such as duck confit with sweet potato dumplings and pan-seared redfish with jambalaya grits and moonshine butter. VanTrece blanches large collard leaves and rolls the sautéed greens inside them, like a grape leaf presentation.

Greens also star in her country chicken saltimbocca, a beautiful *roulade* of chicken, bacon, greens and cheese, cooked on the EGG. Traditionally found in European cuisines – there's the Italian *braciola*, the French *paupiette* and the Hungarian *rouladen* – VanTrece's version of *roulade* reflects traditional soul food. "You can never go wrong with bacon and greens in a dish!"



“Meals of good food with good people are markers in your life. You remember them vividly.”

Country Chicken Saltimbocca

Ingredients

3 6-8 oz (170-225 g) chicken breasts
 4 cups (960 ml) cleaned and destemmed collard greens
 6 slices cooked Applewood-smoked bacon, crumbled
 2 tbsp (30 ml) extra virgin olive oil
 2 cloves garlic, minced
 3 slices aged cheddar cheese

Seasoning Mix

1 tbsp (15 ml) garlic powder
 1 tbsp (15 ml) onion powder
 1 tsp (5 ml) white pepper
 1 tbsp (15 ml) seasoning salt

Basil Cream Sauce

4 tbsp (60 ml) butter
 4 tbsp (60 ml) flour
 2 cups (480 ml) half-and-half
 Reserved liquid from chicken
 1 tbsp (15 ml) smoked paprika
 6 leaves of basil

Method

Set the EGG for indirect cooking with the convEGGtor at 350°F/177°C.

Pound chicken breasts until ¼ inch thick. Mix all seasoning ingredients together; coat chicken breasts with ¾ of the seasoning mix; set aside.

Chiffonade collard greens into strips no wider than ¼ inch. Heat a Cast Iron Skillet with the olive oil. Add greens, then garlic and the remaining seasoning mix, cooking until wilted, 5-7 minutes.

Lay out the chicken breasts with the interior side up. Layer each in the following order: one slice of cheese, ⅓ of the bacon crumbles, ⅓ of the cooked collards. The bacon and collards should be placed in a thin even layer across the whole breast. Beginning at the short tapered end, roll up each chicken breast as you would for a jellyroll. Secure with a toothpick.

Place rolls in a Roasting & Drip Pan, evenly spaced with room between each roll. Place the pan on the grid and bake for 15 to 20 minutes or until the chicken is firm.

Remove from the EGG and allow to rest for at least 5 minutes. Remove the chicken from the pan; reserve the liquid for the sauce. Remove the convEGGtor and grill each side of the chicken for 1 minute for color and added flavor. Gently slice each roll into pinwheels, no less than ½ inch wide. Top with sauce and serve.

Basil Cream Sauce

Melt butter in a sauce pan. Whisk flour into butter. Cook for 90 seconds once incorporated, continuously whisking. Slowly add half-and-half, whisking in each addition until incorporated in flour mix. Season to taste. Add the reserved chicken liquid the same way. Add smoked paprika and cook at a low simmer for 2 minutes, or until it's at the thickness you desire; remove from heat. Chiffonade basil, add to warm sauce just before serving.

Roasting & Drip Pans

The anodized aluminum Roasting & Drip Pans feature an easy to clean surface and have the Big Green Egg logo embossed in the bottom of the pan.



The Rectangular Drip Pan works perfectly with the Rib and Roast Rack for cooking turkey, roasts, chickens and other larger cuts of meat. The Round Drip Pan works well with the Vertical Roasters.

This heavy-duty, Cast Iron Sauce Pot is perfect for melting butter or warming marinades or barbecue sauce. The no-mess basting brush conveniently nests into the pot handle, and the removable silicone brush head is dishwasher safe for easy cleanup!



ELI GUR: PLAYING WITH FIRE

The first time I smoked meat on the EGG, I knew that I would never look back. There's something about it that's almost unexplainable. It just makes you go 'wow.'

Look up “Israeli cuisine” and you’ll find that outdoor barbecuing – or *al ha-esh* (“on the fire”) – is described as an Israeli pastime. For Eli Gur, it’s more than a pastime – it’s the passionate and intense focus of almost all of his spare time.

Born and raised in Haifa, but now living in Binyamina, Eli’s family favorites were all kinds of meat, especially beef, poultry and seafood. “Cooking has always been part of my socializing,” says Eli. More than a decade ago, he began smoking meat on various types of smokers, but the EGG always intrigued him.

“The first time I smoked meat on the EGG, I knew that I would never look back,” says Eli. “There’s something about it that’s almost unexplainable. It just makes you go ‘wow.’”

According to Eli, it’s the consistent temperature control of the EGG that really stands out. Eli knew this from his regular use of the EGG but, true to his training as a software engineer, he wanted to prove it, so he recently conducted experiments to test the heat retention and duration of his XXL Large EGG. “The EGG maintained the correct temperature for hours and hours in every test,” says Eli. As for flavor, Eli invited friends to a blind taste-test of briskets cooked on both the Big Green Egg and a different cooker, and he wasn’t surprised that brisket on the EGG was the top choice among all the tasters. Eli knew the EGG had a technical and materials

quality advantage over the other brand of cooker, so the blind tasting was the only validation he needed. In addition to brisket, Eli’s other favorites on the EGG include chicken thighs, bone-in short ribs, baby back ribs, shrimp and salmon. More “gourmet” dishes he likes on the EGG are smoked goose breast and smoked beef rump-cap.

In 2013, Eli started “Meat & Eat” to host events in a casual social environment and in 2015 he opened “Meat School,” to help beginners learn more about smoking meat. Today, his workshops – usually about 12 people for 4 hours – take place every two to three months. They’re intensely hands-on, and held on the rooftop of his house. “I give a detailed, scientific explanation of the steps, but each person has the opportunity to practice them on their own,” says Eli. “They leave with the kind of knowledge they need to improve their technique right away. And they also know they’re welcome to text me and ask questions!”

Eli strongly supports getting to know the sources of your provisions and buying from local suppliers. “You will be much more appreciative of the origin of your meat if you know how the breeders raise and treat their herds,” says Eli. “The people I work with really love their animals – it’s that simple. I even go to my favorite supplier’s aging room and pick my own cuts. I realize not everybody can do this, but learn more about local farmers and ranchers and if you are not near a farm or ranch, you can still find and establish a good relationship with a local butcher – you’ll get your money’s worth ten-times over. Give me a good piece of meat and my EGG and I’ll wow you!”



Eli’s personal blog, Mesahekbeesh (“Playing with Fire”), which shares his knowledge about smoking meat, other cooking techniques and recipes, can be found at www.mesahekbeesh.com.

Eli Gur's Beef Lambington

Before I began following the paleo way of eating, I loved to prepare Beef Wellington, a tenderloin on a bed of mushroom duxelles and wrapped in pastry. Once I became paleo, I created this variation that uses lamb instead of the dough.



Ingredients

1 boneless lamb hind leg, 6 to 8 lbs. (2.7 to 3.6 kg)
2 to 3 lbs. (1 to 1.4 kg) beef tenderloin, trimmed of fat
4 ounces (115 g) butter
1 ladle of bourbon, brandy or cognac
8 bulbs (the white part) of spring onions, chopped
2 Kaffir lime leaves, preferably fresh
4 ounces (115 g) mixed mushrooms (forest, champignon, shiitake, etc.), chopped
1 tsp (5 ml) 5-spices blend
1 tsp (5 ml) bee pollen
Freshly ground peppercorns to taste

Brining Solution

1 gallon (4 L) water
1 cup (240 ml) kosher salt
Put the lamb in the brine solution for 48 hours, then rinse well in cold water and pat dry.

Method

Set the EGG for direct cooking without the convEGGtor at 350°F/177°C.

Season the tenderloin with the ground pepper. In a cast iron skillet, melt about half of the butter until brown but not burned. Add the tenderloin, turning it so that each side gets a nice brown crust. Carefully add the bourbon/brandy/cognac, and light with a long match to create a flambé. Once the alcohol has burned off, move the tenderloin around the pan to absorb the flavor.

Remove the tenderloin and set aside to cool. Add the onions and kaffir lime leaves to the skillet. When the spring onions are nearly translucent, remove the leaves and add the mushrooms, 5-spices blend, bee pollen and the remainder of the butter. Continue stirring until the mushrooms are tender. Set the mixture aside to cool completely.

Spread the lamb on the counter, internal side up. Add a medium-thick layer of the onion/mushroom filling to completely cover the meat. Place the tenderloin over the filling. Roll the lamb over the tenderloin; tie the rolled lamb with butcher's twine.

Add the convEGGtor and reduce the temperature of the EGG to 225°F/107°C. Place the rolled lamb on the grid and smoke for about 3 hours, until the internal temperature of the lamb is 140°F/60°C and the tenderloin is 132°F/55°C. Remove the convEGGtor and raise the temperature to 400°F/204°C. Cook the lambington on the grid for 2-3 minutes per side for a delicious external crust. Let rest for 10 minutes, then slice and serve.



Easily transform your EGG into an outdoor convection oven.

The convEGGtor is designed to facilitate indirect cooking on the Big Green Egg by providing a heat-directing barrier between the food and the charcoal, easily transforming your EGG into an outdoor convection oven. The design of the convEGGtor, in conjunction with the thermal properties of the EGG, allows heat to efficiently radiate within the dome and prevents the direct flames and heat from overcooking the food.



JASON LILLEY:

THERE'S A WHOLE LOT OF SMOKING GOING ON

Jason Lilley is not your average “town baker.” A pastry chef by trade, Cape Town’s hippest baker has been reinventing the classics with a distinctly South African twist for more than a decade.

A Swiss Hotel School graduate, Jason arrived in Cape Town in 1999 intent on learning a variety of culinary skills. He worked in several pastry kitchens, including on the grand QE2 ocean liner, creating pastries for up to 1,000 diners at a time, before being asked to join the QE2’s VIP restaurant, The Queen’s Grill. After his year at sea, he became head pastry chef at a well-known resort and spa in Knysna, South Africa, where he soon discovered his passion for artisanal bread baking. Jason’s love of “real bread” gave rise to his nickname and Instagram handle, “Captain Bread.” In 2007 he returned to Cape Town and opened a bakery with a fellow chef. Fast forward four years and the first Jason Bakery was born, with a second location opened in 2017.

Artisanal bread and innovative pastries such as the “cronut” – a croissant-doughnut mashup – require significant skill and time. Fortunately, smoking a 7-pound brisket for 12 hours in a Big Green Egg is a lot easier. And at Jason Bakery, there’s a whole lot of smoking going on in addition to the baking.

In 2013, Jason spotted a Big Green Egg on social media and instantly said to himself: I need one of those. “I did a lot of research before buying one, so I was very aware of the wide variety of food that could be cooked on an EGG,” says Jason. “I mean,

even baked cheesecake – what’s not to love about that kind of versatility?” Jason spoiled himself with one of the first XL Big Green Eggs available in South Africa. He cooks right outside on the sidewalk at his original Bree Street location and has an EGG in the kitchen in his new restaurant.

As a savvy restaurateur, Jason finds value in the EGG and its broad range of accessories. “The EGG is super economical when used with the Natural Lump Charcoal and has more accessories than you can shake a stick at. Most importantly, with an EGG, you can go from low and slow smoking a brisket for 12 hours to cooking a pizza in less than three minutes at higher temperatures. I regularly use my EGG for grilling burgers – they’re offered every Friday at the restaurant – as well as chicken wings and grilled octopus. Smoking brisket, baby back ribs and whole chickens are some of my favorites, as are baking pizzas, rolls and loaves of bread.”

Jason spoiled himself with one of the first XL Big Green Eggs available in South Africa. He cooks right outside on the sidewalk at his original Bree Street location and has an EGG in the kitchen in his new restaurant.

Jason Lilley's Smoked Brisket Roll



Jason uses the EGG to smoke the brisket for his Bardough Brisket Roll, a popular offering at Jason Bakery. The brisket roll recipe is a marriage between slow cooked beef brisket and a beautifully baked country loaf.

Ingredients

1 brisket flat, fat cap on, about 6 lbs (2.7 kg)
1 cup (240 ml) brisket rub – see recipe below
½ bag Jack Daniel's wood chips, soaked overnight in water
Bardough House Slaw – see recipe below
10 country loaf rolls – scan the code for recipe
Salted farm butter for the rolls



Scan QR code for
Jason Lilley's Country
Loaves recipe

Rub

1½ cups (360 ml) brown sugar
1 cup (240 ml) kosher salt
1 cup (240 ml) ground espresso beans
¼ cup (60 ml) freshly ground black pepper
¼ cup (60 ml) garlic powder
2 tbsp (30 ml) ground cinnamon
2 tbsp (30 ml) ground cumin
2 tbsp (30 ml) cayenne pepper
Combine all ingredients and store in an airtight container.

Bardough House Slaw

1½ cups (150 g) green cabbage, thinly sliced
1½ cups (150 g) red cabbage, thinly sliced
1¼ cups (150 g) julienned carrots
⅓ cup (40 g) dried cranberries
2 tbsp (30 ml) mustard
1 cup (240 ml) mayonnaise
Salt to taste
Mix all slaw ingredients together and refrigerate.

Method

Coat the brisket on all sides with an even layer of rub. Let the meat rest for 1 hour at room temperature or until the rub starts to turn pasty.

Set the EGG for indirect cooking with the convEGGtor at 225°F/107°C.

Place the brisket, fat side up, on the grid. After 8 hours check meat periodically. When the brisket reaches an internal temperature of 200°F/93°C, remove it from the EGG onto a rimmed baking sheet to rest for 30 minutes.

Cut the brisket in thin slices against the grain. Cut the rolls in half and butter on both sides. Add sliced brisket and slaw and enjoy! Serves 10.

Know the Heat!

A quality digital thermometer is a necessity when cooking meat or poultry to safely monitor the internal temperature. Remember, you can't tell if food is safely cooked by looking at or touching it!



The Remote Wireless Thermometer monitors temperatures from a distance of up to 300ft / 91m. Includes preset temperatures for all of your favorite foods.



The Instant Read Digital Food Thermometer gives a quick readout of the internal temperature of foods.

The Digital Food

Thermometer quickly monitors the temperature of food and fits conveniently in your pocket.



The Professional Infrared Cooking Surface Thermometer safely measures the temperature of cooking surfaces without contact for precise heat control. Aim the precision laser light beam at pizza stones, griddles or cooking grids to read the surface temperature before adding the food.

ANDREA BEMIS

Almost anything from our harvests year-round is **so good grilled on the EGG**. Cook in season, keep it simple and just enjoy what nature – and your local farmer – has put in front of you.



Now a farmer of six acres in Parkdale, Oregon, on which she and her husband Taylor grow fifty varieties of vegetables, Andrea Bemis grew up never having even mowed a lawn or weeded a backyard garden, much less spending long days bent over using her hands in the earth.

“I grew up outside Portland and had the typical suburban childhood,” says Bemis. “When Taylor and I went to work on his family’s farm in Massachusetts, I had absolutely no idea what it would be like to spend day after day outside, in both pouring rain and blazing heat. I’m used to it now, although I certainly still have days when my back is breaking but I say to myself, ‘I just can’t let this squash beat me!’”

Bemis refers to herself as a farmer-eater-lover. She firmly believes that “food is medicine” and sometimes still wonders how on earth she fell in love with her beautiful yet harsh existence. It’s one she clearly loves, but she takes regular respite from it by developing recipes and cooking, and her EGG fits into the plan perfectly. “I create recipes in my head while I’m out gathering vegetables. I don’t know on any given day what we might be eating that night, at least

not until I get into the fields. A lot of farming is monotonous, so I have time to fantasize about what I’m going to cook for dinner.” Bemis has collected her recipes into her first cookbook, “Dishing Up the Dirt,” which focuses on cooking through the seasons. Her recipes range from the simplest of the simple – such as grilled baby bok choy with ginger sesame sauce – to those that require a bit more skill, such as rustic peach thyme galette with almonds and honey yogurt.

“Most of the recipes are quite easy and intended to showcase the natural flavor of an ingredient that’s in season,” says Bemis. “I want to set people up for success in the kitchen with an understandable, ‘approachable’ recipe. Fresh food tastes wonderful and it doesn’t need a lot of doctoring. And you don’t have to grow your own food to eat this way!”

In 2017, Tumbleweed Farm raised its first pigs. The meat from the pigs wound up in Bemis’s first harvest dinner, in October, held in the farm’s tractor barn. Cooked on her large EGG, the smoked pork shoulders were served to 25 friends and neighbors along with other food cooked on the EGG – sourdough bread, bruschetta



Grilled Baby Bok Choy with Ginger Sesame Sauce

Recipe adapted from **Dishing Up the Dirt: Simple Recipes for Cooking Through the Seasons**, published by HarperCollins Publishers.

"Throughout the year, the farm is overflowing with a variety of greens," says Andrea. "This bok choy is so simple and so flavorful and is a great side for grilled chicken or fish. Almost anything from our harvests year-round is so good grilled on the EGG."

Ingredients

4 heads baby bok choy
2 tbsp (30 ml) olive oil
2 tsp (10 ml) minced fresh ginger
3½ tbsp (53 ml) low sodium soy sauce
2½ tbsp (38 ml) rice vinegar, unseasoned
1½ tsp (23 ml) honey
1½ tsp (8 ml) sesame oil
1½ tsp (8 ml) toasted sesame seeds

Method

Set the EGG for indirect cooking with the convEGGtor at 350°F/177°C.

Trim the large leaves from the bok choy; slice larger heads in half lengthwise, and keep smaller heads whole. Rinse the bok choy under cold water to remove any remaining dirt. Pat the bok choy dry, toss it with the olive oil and place it on the cooking grid to cook until tender, browned and lightly charred on all sides, 10 to 12 minutes.

Whisk together the ginger, soy sauce, vinegar, honey, sesame oil and sesame seeds. Taste and adjust the sauce as necessary. Drizzle the grilled baby bok choy with the sauce and enjoy.



The Big Green Egg stainless steel Kitchen Shears are ideal for a multitude of tasks, from trimming poultry, meats and seafood to snipping herbs and cutting flowers and vegetables.

with cherry tomatoes, pumpkin for a soup. "It was a wonderful meal and a beautiful, magical night. It fit our philosophy so well: When you sit down to a good meal with good people you can slow down and really be present for the moment. Because we farm daily for nine straight months, a harvest dinner is realistic only once a year, but we use the EGG routinely and love the versatility it gives us. We're really dirty at the end of a day's work and it's great to be able to light up the EGG, kick back and cook outside over fire. It's perfect for our life on the farm."

If you're in the Portland area, most months you can find Andrea and Taylor at Migration Brewery once a week, delivering their community-supported agriculture (CSA) boxes of vegetables to customers. The idea of the CSA model is to connect the producers and the consumers in the food chain in a closer way. "All of our customers were strangers at the beginning, but now we feel like they're on this journey of fresh food with us," says Bemis. "And what a journey it's been. We've now been doing this for nine years and I still get giddy when we're picking beautiful vegetables that were just little seeds in the greenhouse months before."

Specialty Cookware

The Stir-Fry & Paella Grill Pan is perfect for creating traditional paella recipes as well as delicious stir-fry meals! Experiment with different meats, poultry, seafood and seasonal vegetables to create your own interpretations of these popular international dishes.



Perforated Grill Woks make it easy to cook vegetables, meat, seafood or any other smaller pieces of food that might slip through the standard cooking grids.

WILDFIRE ON TOUR A DREAM COME TRUE

The EGG makes the entire cooking process so easy and it always ensures delicious results. Meat stays extremely succulent and the temperature stays consistent.

Way back in 1993, Thomas Eriksson-Frohlich travelled from Germany to attend a small backyard barbeque contest in America. A self-professed music roadie, he was there to check out the music, but it was the barbequed meats that hooked him. Back home, Eriksson-Frohlich and a friend built a smoker, but his first try at smoking meat didn't go so well – “I ended up ordering pizza for my friends that I had invited, because absolutely nothing was edible.” Still, he never forgot the taste and experience he had in the U.S., and he kept trying, describing his efforts as “learning by burning.”

After years traveling the U.S. and talking to every pitmaster who would take the time, Eriksson-Frohlich got so good at smoking meat that he became a barbeque judge, started what would become one of Europe's top barbecue teams, Flaming Pig BBQ, and opened a restaurant. When he met his now-wife, Jenny, they moved to her home country of Sweden and decided to “do barbeque” full-time – the restaurant, catering and classes. “In Sweden,” says Thomas, “introducing people to barbeque was real pioneer work.”

The couple cooked all of their meat in either a brick pit or on a smoker. Once Thomas was introduced to the EGG, in 2011, he knew he had found what he had been looking for, and immediately gave up his intensive research on other cookers and has been using an EGG ever since. “The EGG makes the entire cooking process so easy and it always ensures delicious results. Meat stays extremely succulent and the temperature stays consistent. For a dish with a long cooking time, you can simply go and do something else while the food cooks because the EGG is incredibly efficient and does not need to be refilled with charcoal constantly. The flavor

from the Big Green Egg charcoal is incredible. We also do a lot of side dishes on the EGG, such as potato gratin, as well as appetizers and finger foods.”

Eventually, Thomas and Jenny got interested in competitions, going to the first Kansas City Barbeque Society (KCBS) events held in Europe (and competing every year since) and winning the prestigious Tony Stone Low & Slow Competition in 2016 – “A dream come true,” says Thomas. The Eriksson-Frohlichs were even instrumental in founding Scandinavia's first KCBS competition, Smoke in the North.

In 2016, needing more time with their two children, Thomas and Jenny closed the restaurant to pursue their barbeque passion in a different way. Big Green Egg Europe bought a Mercedes truck that had served for 30 years as a fire emergency vehicle in Germany, and had it modified to serve as their touring vehicle for their new project, Wildfire on Tour, to enter competitions and offer workshops and demonstrations throughout Europe. The couple's home-on-the-road also serves as a classroom/outdoor kitchen/competition stage and pulls a trailer that has all seven sizes of the EGG on board.

“We live and breathe barbeque,” says Thomas. “For us, it's not a trend – it's a passion we love to share with our daughters, friends and strangers. We can't even think about a life without cooking on the EGG. People called us crazy when we decided to take Wildfire on Tour, but it works for us – and thanks to Big Green Egg we're living our dream.”

You can follow Thomas and Jenny on Facebook at Wildfire on Tour, at wildfireontour.com and on Instagram using [#wildfireontour](https://www.instagram.com/wildfireontour).



Glazed Pork Belly with Sweet Potato



Ingredients

1¼ lbs (800 g) pork belly
Agave nectar for drizzling
Sea salt flakes
12 small sprigs of thyme

Glaze

1 cup (240 ml) peach jam
½ cup (120 ml) barbecue sauce
3 tbsp (45 ml) bourbon whiskey
3 tbsp (45 ml) agave nectar
3 tbsp (45 ml) flower honey

Rub

6 tbsp (90 ml) smoked paprika powder
2 tbsp (30 ml) dried thyme
1 tbsp (15 ml) garlic powder
1 tbsp (15 ml) onion powder
1 tbsp (15 ml) freshly ground black pepper
2 tbsp (30 ml) muscovado sugar or brown caster sugar
1 tbsp (15 ml) ground ginger
Pinch of chili powder

Sweet Potatoes

6 sweet potatoes
7 tsp (35 ml) ground cinnamon
1½ cups (300 g) butter + extra for greasing the pan

Method

Set the EGG for direct cooking without the convEGGtor or grid at 375°F/191°C.

Put all ingredients for the glaze in a pan and bring to a boil on the stovetop while stirring often. Turn the heat to low and simmer gently for approximately 10 minutes.

Remove most of the fat from the pork belly, allowing a layer of ⅛ inch (3-4 mm) to remain. Score the fat crosswise. Mix all ingredients for the rub together. Lightly rub the pork belly with the rub, reserving about ⅓ of the rub, and drizzle with agave nectar. Sprinkle with sea salt flakes and rub into the meat.

Sprinkle a handful Pecan Smoking Chips on the charcoal embers and add the convEGGtor for indirect cooking with a Cast Iron Grid (flat side up). Lay the pork belly fat side up on the grid and close the lid of the EGG. Stabilize the temperature at 325°F/165°C and smoke for 35-40 minutes.

With a basting brush, coat all sides of the pork belly with the glaze, reserving about ⅓ of the glaze. Continue to cook until the internal temperature of the pork reaches 165°F/74°C. Remove from the EGG and loosely cover with foil. Raise the temperature of the EGG to 375°F/191°C.

Wash and pat dry the sweet potatoes; cut in half lengthwise. Grease a Cast Iron Skillet with butter and add the potatoes, cut edge up. Dust with 6 teaspoons of cinnamon; cut 1 cup (225 g) of butter into thin slices and arrange over the potatoes.

Cover the skillet with foil and place in the EGG; cook the potatoes for 45 minutes until the flesh is soft. Meanwhile cut the pork belly into 1½ inch (4 cm) cubes and lay them on the Cast Iron Plancha Griddle. Top with the remaining glaze and rub.

Remove the Cast Iron Skillet with the potatoes from the EGG and place the Cast Iron Plancha Griddle with the pork on the grid. Grill for approximately 5 minutes until the glaze is caramelized and the pork is hot.

Scoop out the cooked flesh of six potato halves and place in a bowl. Cut the remaining butter into cubes and add to the potatoes. Sprinkle with the remaining cinnamon and fold in gently. Scoop a sixth of the mixture onto each potato half. Garnish with the thyme and serve with the pork belly. Serves 6.

EGGMitt® BBQ Glove

The EGGmitt BBQ Glove prevents heat from entering the soft cotton inner layer. Features an extra long cuff for ultimate protection.

Heat-Resistant, Super-Flexible Silicone BBQ Mitt

The Silicone BBQ Mitt withstands extreme heat and features an FDA-approved, BPA-free waterproof silicone exterior and a soft, comfortable cuff and lining.



HUMBLE PIE: PIZZA AND BAKING ON THE BIG GREEN EGG

In 1905, an Italian immigrant named Gennuaro Lombardi is said to have opened the first American pizza shop on Spring Street in New York. For about the next 40 years, pizza was considered a “foreign” food and had a limited following among the general population. But when a wave of soldiers from World War II came back to the U.S., pizza became popular as they spread the word about this flat pie they had eaten and loved in Italy (particularly Naples, where the first known pizza shop opened in the 1800s). Pizza became mainstream in the 1960s, with the invention of frozen pizza and pizzerias offering just-cooked pizza-by-delivery. Along the way pizza became a food with a huge following, with passionate people on all sides of the debate about the “perfect” crust and the “right” toppings ... “Chicago Style” anyone?! Once well-known chefs began making it a central part of their offerings, suddenly pizza ovens were a mainstay in restaurants around the world, from the corner deli to Michelin-starred restaurants.

Brick Oven Goodness – Without the Brick Oven

Thanks to the Big Green Egg, you don’t need a wood-fired brick oven in your backyard to get the best pizza – everyday grillers as well as chefs around the world know that the EGG performs like a super-efficient firebrick oven. In fact, EGG owners know a secret ... that the Big Green Egg bakes better than wood-fired



ovens ever could, because heat from the natural charcoal radiates in a convective flow within the thick ceramic walls of the dome, allowing your food to bake quickly and evenly. There’s no need to buy a high-priced pizza oven or any kind of an “insert” or separate apparatus, either ... you can bake and roast your way to culinary perfection by cooking with indirect heat simply using the convEGGtor and a Pizza & Baking Stone in your EGG!

Our complete line of flat and deep dish Pizza & Baking Stones makes it easy to perfectly bake a variety of recipes, from artisan breads, casseroles, quiche and lasagna to pastries, pies and desserts. Our baking stones are made to the same exacting specifications as the EGG itself, so they distribute heat evenly for better baking and browning, and the ceramics pull moisture from the outer surface of the dough for delicious brick oven crispiness. And, because the stones retain heat so efficiently, your foods conveniently remain warm longer.

Baking is only one of the indirect cooking techniques you will enjoy. Roasted meats such as poultry, beef, hams and other foods are naturally tastier because the flavor stays locked inside. While the ancient Pompeii ovens relied on bricks and clay to hold heat, today’s Big Green Egg uses patented components and insulating ceramics to retain heat and moisture so well that foods just don’t dry out. When baking or roasting on the EGG, food cooks faster with consistent browning and moister results ... you may never cook indoors again once you experience how your Big Green Egg achieves better results – with more intense flavor – than any other type of oven.

Everything tastes better cooked in an EGG, especially pizza ... amore al primo morso!



Tips for The Ultimate Pizza on the Big Green Egg



Peter Reinhart is a baking instructor at Johnson and Wales University in Charlotte, North Carolina, and the author of eleven acclaimed books on baking, including “American Pie: My Search for the Perfect Pizza”, “Brother Juniper’s Bread Book” and the modern classic “The Bread Baker’s Apprentice.”

Here are some of Peter’s tips for the perfect pizza on the EGG:

- On the day you plan to make the pizzas, remove the dough from the refrigerator about 3 hours before you plan to start cooking so it can slowly wake up and relax.
- Your sauce should not be too thick as it will evaporate some when it bakes. You do not need a lot of sauce and you do not need red sauce. Pesto, white or brown sauce, or just cheese without sauce are viable options. Fresh clams, tossed in garlic oil and spices – as made justifiably famous at Frank Pepi’s Pizzeria in New Haven, Connecticut – is an amazing topping with just cheese and no red sauce.
- I prefer a blend of three cheeses. One is a fresh hard cheese (not boxed or pre-grated) such as Romano, Asiago, Parmesan or Sonoma Dry Jack. The second is a good “melter” such as mozzarella, Monterey Jack, cheddar, Fontina, provolone, or Gruyere. The third can be any favorite, including some version of blue cheese. I grate or shred them with one part hard cheese to two parts “melter,” and one part optional. Then I mix in a few teaspoons of a variety of dried or fresh herbs and spices such as basil, oregano, thyme, herbs de Provence, black pepper and granulated or fresh garlic. This blend gives the cheese a more interesting appearance and boosts the herbal flavor of the sauce.
- An easy grilled pizza to try is a simple Margherita-style sauce and cheese pizza. You can always add toppings and get more inventive once you master a basic pizza and, frankly, many people still prefer this classic to all the other types. For this pizza, top with a garnish of 3 or 4 fresh basil leaves that have been cut into slivers just before serving.
- Less is more – but make the less truly more by using quality ingredients ... and an EGG!



Scan for more about creating the perfect pizza dough, and for Peter Reinhart’s recipe for Neapolitan Pizza on the Big Green Egg.

Pizza and Baking EGGcessories



The **Ultimate Pizza Wheel** features a durable stainless steel rotary blade for perfect slices and a non-slip grip and integrated blade guard for safety. The cutter disassembles for easy cleaning in the dishwasher.



The **Aluminum Pizza Peel** features a smooth and sturdy aluminum surface with a comfortable soft grip handle. Keeps hands away from the heat and provides a convenient way to handle pizza, calzones and bread.



The **Pizza Slice Server** handles your creations like a pro. The extra-wide stainless steel blade is ideal for easy handling of galettes, pizza, pie, appetizers and more. Oversized soft grip handle for comfort and control.





JOHN COX REFINED RANCH CUISINE

Photo courtesy of Kodiak Greenwood

John Cox credits a great-uncle with introducing him to good food and wine during his early years in Dallas, Texas. His uncle (“Today, we would call him a real ‘foodie,’” says Cox) traveled extensively, including in Europe, and ate in just about every restaurant that opened in Dallas. At holidays, he would take the family to a Dallas hotel noted for a lavish array of gourmet foods.

“It was eye-opening for me,” says Cox, “I was only six or seven at the time, and it made an impression.” At home, the Cox family ate in typical Dallas-suburb style. “We smoked a lot of meat, of course, because there’s nothing more Texas-like than cooking over a fire. A lot of the love of food and cooking is sensory recall and there are few things in my life that evoke a stronger memory of family than the wonderful aroma of great food cooking over natural charcoal.”

When his family moved to New Mexico, Cox got a paper route and saved his \$30 a month earnings to visit the top restaurants in Santa Fe that he had read about in a local dining guide. “A friend and I would take a bus downtown and we would get out and buy a few appetizers in each restaurant,” says Cox. “It was my way to explore the local dining scene.”

After high school, Cox was accepted into the prestigious New England Culinary Institute in Montpelier, Vermont, making his way after graduation back west to restaurants in California. From 2012 to 2016, he was executive chef at Sierra Mar, the highly acclaimed restaurant at the Post Ranch Inn in Big Sur. He also became a chef-partner at Cultura, in Carmel-by-The-Sea. Several years ago, Cox attended a culinary event in Savannah, Georgia, and was introduced to the Big Green Egg. He experimented with an EGG enough to

immediately know that he wanted one for his next big adventure: a partnership with the famous Fess Parker family to open The Bear and Star restaurant, featuring “refined ranch cuisine,” in Los Olivos in Santa Barbara county.

The Bear and Star is more than just a trendy new “farm-to-table” destination restaurant. Cox and members of the Parker family are building a true food ecosystem on the family’s 714-acre ranch. Although the cattle operation has been around for more than 20 years, and has 150 head of Wagyu cattle and 60 head of sheep, the ranch now also has 300 acres of grapevines, 400 acres devoted to an organic vegetable farm, an orchard and a bee-keeping operation. The ranch provides 100 percent of the restaurant’s beef, lamb and eggs from quail, chickens, and ducks. In peak harvest season, about 30 to 40 percent of the produce used is from the ranch, with the goal being 100 percent in a year or two.

In summer, the restaurant hosts a regular outdoor music series and fires up its XL EGG out back, cooking everything from lamb kabobs to tacos. “Believe it or not, we cook for 100 people using that one EGG,” says Cox. “My partner at Cultura, who is a plant-based chef, may love the EGG even more than I do. She smokes beets, turnips and other root vegetables on it. We also use it for smoking pork for our signature Cultura Mole of pork, sesame and orange. The versatility and range of what we can do with our EGG is unlike any other grill.”

Cox recently bought a Mini EGG for the boat on which he lives in the Santa Barbara harbor. “I don’t want to be too far away from an EGG, and the Mini is perfect for the boat!”



Grilled Steelhead Trout over Wild Fennel Fronds

Steelhead trout is similar to salmon in its color and texture and is a great choice to cook on the EGG. The convection heat that radiates within the dome caramelizes the fish nicely and the fennel gives it a fresh, sweet, licorice flavor.

Ingredients

2 1-lb. (.5 kg) steelhead trout filets, skin on, pin bones pulled
1 Meyer lemon (cut in half on equator)
2 tbsp (30 ml) sea salt
1 tsp (5 ml) wild fennel pollen
1 tsp (5 ml) ground Espelette pepper
2 tbsp (30 ml) olive oil (preferably herbaceous and spicy)
1 bunch fennel fronds and stems

Method

Set the EGG for direct cooking without the convEGGtor at 350°F/177°C with a cast iron grid, flat side up.

Squeeze one side of the lemon onto the two filets. Season the filets with salt, fennel pollen and espelette. Drizzle the olive oil over the filets and gently massage to work into the flesh. Slice the remaining lemon half and lay over the steelhead.

Place the fennel directly on the cooking grid. Put the steelhead, skin down, on the fennel. Close the dome and let the fish cook for 7-8 minutes. The fish is done when the flesh has turned a pale pink and flakes to the touch. Serves 4-6

"There are few things in my life that evoke a stronger memory of family than the wonderful aroma of great food cooking over natural charcoal."

Big Green Egg Cast Iron Cookware

Designed with oversized, easy-to-grip handles and built to deliver a lifetime of cooking enjoyment!

Dutch Oven

The traditional cast iron Dutch Oven is a favorite for cooking stews, soups, chili and cobblers on the Big Green Egg.



Plancha Griddle

The dual-sided design of the Plancha Griddle is ideal for searing meats and seafood, sautéing vegetables and even grilling sandwiches and paninis. The Plancha Griddle is also perfect for cooking breakfast ... use the flat side for pancakes and eggs, the ridged side for sausage and bacon.



Deep Skillet

Perfect for searing, braising, baking, sautéing or roasting ... the Cast Iron Skillet will delight you with the results! Use in your EGG for everything from seared steaks and seafood, casseroles and braised meats to cornbread, biscuits and cobblers.



LOST VILLAGE FESTIVAL

EGGS IN THE WOODS



Richard Turner “King of London’s Carnivores”

Richard Turner is a very busy man. He is chef at three restaurants – Hawksmoor, Pitt Cue Co. and Blacklock – owns a butcher shop and has written four cookbooks. He also guided the expansion of Meatopia – an event built on the celebration of nose-to-tail meat, artisan ales and communing around real fire – to the U.K.

Turner gives credit to his time as a very young man in the British Army for his love of beef – in fact, he told *The Guardian* in a 2016 interview that he joined the Army boxing team because they were served steak for breakfast. Fast forward a number of years and Richard “badgered” his way into a job at Le Gavroche, a Michelin two-star restaurant in London, which was followed by stints at several other top restaurants, and then to Hawksmoor, which he envisioned as a new type of steakhouse.

And along the way, he was introduced to the Big Green Egg. “There’s a crazy alchemy that goes on inside the EGG: you set the temperature, close the lid and boom, you get the best tasting meat you’ve ever experienced! I’ve been a fan from day one.”



Scan the code to read more about
Big Green Egg’s “Steak Out” at Meatopia.

Not your average festival. Not your average setting. And most definitely not your average cooking in the woods.

The annual Lost Village Festival, held in Lincolnshire, U.K., delivers an “immersive” festival experience in an abandoned woodland village, including dancing in the Abandoned Chapel, learning new skills on Forger’s Lane, comedy shows at the Lost Theater, music under the stars ... and a passion for good food, including some cooked by several of the U.K.’s most innovative young chefs, all taking place in a majestic and mystical setting in the woods.

A highlight of the Festival are the Tribal Banquets, offered this year by award-winning chefs Lee Westcott (Typing Room), Elizabeth Allen (Pidgin) and James Lowe (the Michelin-starred Lyle’s). The Big Green Egg was requested by all three chefs to deliver perfection in cooking a specially curated and changing banquet menu every night for 100 lucky attendees.

The two XL EGGs were pivotal in providing incomparable flavor for the chefs’ meals, to say nothing of logistical cooking power in a woodland kitchen setting. The nightly menus featured the EGGs in a variety of ways – Elizabeth Allen and Lee Westcott cooked lamb rump with lamb ragu, pickled cabbage and brioche for their main course, and James Lowe cooked wing rib, from Cornwall’s famous grass-fed Dexter cows, with kale and anchovy.

The final night featured Richard Turner, executive chef of London’s globally renowned Hawksmoor restaurant, who completed the weekend’s exceptional culinary lineup with his award-winning Hawksmoor Sunday Roast, a charcoal-roasted rib of beef with golden garlic, accompanied by Yorkshire pudding.

Lost Festival claims that “those on the outside will never understand.” Those who were there surely do now understand the magic of this event and the magical results of EGGs in the woods.

There’s a crazy alchemy that goes on inside the EGG: you set the temperature, close the lid and boom, you get the best tasting meat you’ve ever experienced!



On the Cover: The Perfect Steak



Ingredients

2 ribeye or strip steaks, 1½ to 2 inches (4 to 5 cm) thick
Big Green Egg Ancho Chile & Coffee Seasoning

Method

Trim the steaks of any excess fat. Apply the seasoning to both sides of the steaks. Allow to stand at room temperature for 30 minutes before grilling.

Set the EGG up for direct cooking without the convEGGtor at 650°F/343°C. To increase sear marks, use a cast iron cooking grid.

Place the steaks on the grid and sear for two to three minutes. Carefully open the lid and flip the steaks onto a new section of the grid. After two to three more minutes, flip the steaks once more.

Completely shut down the EGG by closing the damper top and draft door. Let the steaks continue cooking for 3 to 4 minutes, until they reach the desired internal temperature (check with a meat thermometer).

Remove the steaks and let them rest for 5 minutes before serving.

New for 2018: Seasonings and Sauces

Introducing the NEW line of Big Green Egg Seasonings! Add flavor to any dish by sprinkling Big Green Egg Seasonings on any of your favorite foods before cooking. For a bolder taste, use the seasonings as a dry rub and apply 30 minutes or longer before cooking, or add them as an ingredient in your favorite recipes. Big Green Egg Seasonings are Gluten Free, MSG Free and Kosher.

Ancho Chile & Coffee Seasoning

A robust blend of poblano peppers and coffee

Citrus & Dill Seasoning

A tropical blend of citrus, herbs and spices

Savory Pecan Seasoning

A nutty blend of sweet and savory flavors

Sweet & Smoky Seasoning

Traditional smoked paprika barbecue flavor

Scan the code for
Amazing Recipes



Cast Iron Cooking Grids

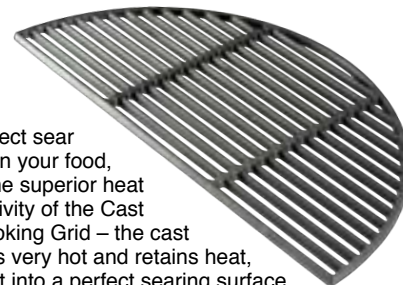

For perfect sear marks on your food, utilize the superior heat conductivity of the Cast Iron Cooking Grid – the cast iron gets very hot and retains heat, turning it into a perfect searing surface. The Cast Iron Grid for the XLarge EGG is a half-moon; pair two together for a full grid.



I love the versatility of the EGG – you can cook your entire meal on it, from scrambled eggs to dessert. And the EGG really enhances the flavors of authentic Mexican cuisine.

You may not know the difference between the cuisine of Baja and Jalisco, or Oaxaca and Veracruz, but chef Claudette Zepeda-Wilkins does. She can tell you that in “El Norte” region, there are at least 40 different types of flour tortillas and that the Mexican states that border the Gulf of Mexico are culturally an arm of the Caribbean, with food that shares the Creole culture of cities such as New Orleans and Havana.

Zepeda-Wilkins knows all of the finer points of Mexican cuisine: Although she was born in San Diego, both of her grandmothers lived in Mexico – one in Tijuana and one in Guadalajara – and she spent much time with them growing up. She was introduced to the restaurant business by spending time in an aunt’s restaurant in Guadalajara. “I was surrounded by *authentic* Mexican food,” says Zepeda-Wilkins. “Typical food in Mexican restaurants in America – tacos, enchiladas, maybe tamales – is a pale imitation of real Mexican food. Most people don’t understand how diverse the cuisine of Mexico is – we’re a mountain culture, seaside culture, plains culture. In

fact, there are 40 distinct regions of cuisine in Mexico. Many know of the Mayan culture in Mexico, but don’t realize that Mexico has a long history of immigration from many other cultures in Europe, the Middle East and the Caribbean.”

Mexicans adapted pasta from the Italians into *fideo*, a traditional pasta and chicken soup. “It’s the soup your Mexican grandmother always makes for you,” says Zepeda-Wilkins. Tacos *al pastor* (English translation: “in the style of the shepherd”) come from the Lebanese influence in the Puebla region in central Mexico. Lebanese immigrants brought their *shawarma* – spit-roasted meat – technique with them and Mexican shepherds adapted the traditional Lebanese



**CLAUDETTE
ZEPEDA-WILKINS**
REGIONAL
MEXICAN
CUISINE

recipe, using pork instead of lamb. A strong Afro-Cuban influence in the states of Tabasco and Veracruz includes the use of peanuts, for dishes such as *pollo encacahuatado* (chicken in peanut sauce), plantains, yucca and sweet potatoes. The Bajío region is renowned for its carnitas and sweet desserts such as *arroz con leche* (rice pudding) and *bunuelos* (fritters). Because of the climate in the valleys of the Baja peninsula, Baja-Med cuisine features vegetables from the Mediterranean region – eggplant, tomatoes, root vegetables, hardy greens.

“Mexican cuisine is truly regional-based,” says Zepeda-Wilkins. “If a certain region doesn’t grow a particular type of corn, for example, they would never think to import it, like we do here in America.”

During the last several years, Zepeda-Wilkins has travelled through the seven major regions of Mexico, researching their cuisines back to the 15th century. She is now bringing authentic regional Mexican cuisine to her position as Executive Chef at El Jardín restaurant in San Diego. A chef in San Diego since 2000, she has worked in some of San Diego’s most well-known

restaurants, as a sous chef, pastry chef, butcher and recipe developer, and also competed on season two of “Top Chef Mexico” in 2016.

Zepeda-Wilkins was introduced to the Big Green Egg when she attended a back-yard barbecue near her husband’s hometown of Athens, Georgia. “Friends cooked a traditional southern dish – smoked pork butt – and it was the best I’d ever tasted,” she says. “I had seen a picture on Instagram of a chef cooking on an EGG and said to myself, ‘What is that thing?’ After my visit to Georgia, I couldn’t wait to get one. I love the versatility of the EGG – you can cook your entire meal on it, from scrambled eggs to dessert. And the EGG really enhances the flavors of authentic Mexican cuisine.”

Claudette Zepeda-Wilkins' Smoked Beef Birria

"This is my family's version of birria – we add fresh ginger, cinnamon and cloves to give it real depth of flavour and a little zing ... and the EGG does the rest."



Jalisco, where some of Zepeda-Wilkins' family is from, is known for supplying much of Mexico's grains, fruits and vegetables, as well as local cheese and chilis. It's also known for birria, a stew of beef, mutton or pork with chili peppers. Zepeda-Wilkins' Smoked Beef Birria uses the stewing technique to make the adobo for the recipe – adding short ribs that have been smoked on the EGG.

Ingredients

8 lbs (3.6 kg) beef short ribs
Tortillas

Adobo

8 guajillo chiles
5 ancho chiles
10 garlic cloves
½ oz (14 g) ginger
2 medium onions
2 cups (480 ml) water
2 tsp (10 ml) freshly ground black pepper
½ tsp (3 ml) ground cloves
½ tsp (3 ml) oregano
8 sprigs thyme
½ tsp (3 ml) ground cinnamon
4 bay leaves
3 tsp (15 ml) salt
4 tbsp (60 ml) vinegar

Optional for Serving

Minced onion
Cilantro
Lime wedges

Method

Set the EGG for indirect cooking with the convEGGtor at 350F/177C.

In a Dutch oven, cook chiles, garlic, ginger and onions in a pot with water, until chiles are tender. Drain the water and process the mixture together with the rest of the adobo ingredients.

Clean the short ribs and marinate in ½ of adobo mix for 2 to 3 hours. Remove from the marinade; add to the grid and smoke for 4 hours. Move the beef ribs to the Dutch oven and cover with the remaining adobo; move the Dutch oven to the EGG and cook for an additional 4 hours. Enjoy with minced onion, cilantro and limes accompanied by tortillas.

Enameled Cast Iron Dutch Ovens

The Enameled Cast Iron Dutch Ovens provide excellent heat retention, making them ideal for slow-cooking, braising, roasting, simmering and baking! With lids that double as an additional cook pot, the durable enameled Dutch Ovens are easy to clean, dishwasher safe and heat-resistant to 450°F / 232°C.





ROBIN WICKENS NEW LEVELS OF CREATIVITY

“The EGG gives us the ability to do everything you can do with an oven, while delivering that clean, smoky flavor. Regardless the season, the EGG is always being used.”

“Fine dining in an Australian bushland setting” sounds almost like an oxymoron. But that is exactly what chef Robin Wickens is offering at Wickens at the Royal Mail Hotel in tiny Dunkeld, Australia. The remote but picturesque town in Victoria, population 678, might be the last place you’d expect to find a four-star hotel and upscale restaurant. But Dunkeld and Wickens’ restaurant are now considered a prime food-tourism destination in Australia.

The offerings at Wickens at the Royal Mail Hotel are grounded – literally – in the one-acre organic garden and the hotel owner’s livestock of sheep, beef and goats. “The garden has 400 varieties of edible plants,” says Wickens. “We aren’t afraid to experiment with different cooking and smoking techniques – it’s part of the way we run a sustainable restaurant and it demonstrates the breadth of cooking that a garden can provide you with.” The menu regularly evolves based on which ingredients are flourishing in the garden so that Chef Wickens can make the most of seasonal produce. About 80 percent of the menu is sourced directly from the garden, but “Regardless the season, the EGG is always being used.”

Wickens was born and raised in the U.K. and worked in several top restaurants before moving to Melbourne in 2000. Known for his intricate, molecular-gastronomy style, Wickens had a string of accolades before he turned 30, including Best New Talent in 2005 by *Australian Gourmet Traveller* magazine, while running his Melbourne restaurant, Interlude. A big part of the attraction of moving to Dunkeld is the area’s variant climate. “It allows for more produce, which means more menu creativity,” says Wickens. “Because we work so truthfully with our kitchen garden, and push ourselves to avoid waste, we often have unusual menu offerings, such as a tomato-based dessert, or an entrée of almost all carrots in a variety of ways.”

Like all good chefs, Wickens is always on the lookout for interesting and new kitchen tools that can take his team to new levels of creativity. When he and the hotel’s owner started to discuss opening Wickens at Royal Mail Hotel, in 2016, he spoke to many different chefs about the tools they love to use so he could put together a great kitchen. “I learned about the EGG from friends in the U.K., where the EGG is very popular. I knew I wanted one for the kitchen here because I wanted a contained charcoal grill that didn’t take up a lot of room in the kitchen. The EGG, and we now have three, gives us the ability to do everything you can do with an oven in a small space, while delivering that clean, smoky flavor.”

“We grill veal rump on the EGG and we also cook dry-aged beef sirloin that has a really good crust and flavor.” But the bounty from the garden is often the star of the EGG, everything from cabbages to white asparagus to a smoked beetroot pureed to accompany duck.

“We’re so fortunate to have this beautiful garden and be able to offer fresh, pure food to our guests. And quite simply, the EGG adds a completely different element to our garden’s produce.”

Grilled John Dory, Oyster, Kohlrabi and Apple



John Dory is well-known as one of Australia's finest eating fish and is found in coastal waters from southern Queensland to southern Western Australia. "I'm a big fan of cooking fish on the bone on the EGG. It surprises some diners that we can prepare such delicate fish directly on the grill, but it comes out beautifully."

Ingredients

2 whole John Dory, 2 lbs. (900g) each, heads removed
4 fresh oysters, unopened
1 granny smith apple
1 green kohlrabi, plus leaf for garnish
Kohlrabi, Apple and Parsley Juice
Oyster Cream
Borage flowers and sheep's sorrel (or parsley) to garnish



Scan the code for recipes for Kohlrabi, Apple and Parsley Juice and Oyster Cream

Method

Using shears remove all spines from the fish, season with salt and oil. On a mandoline slicer, slice the apple and kohlrabi into very thin slices (allow 3 slices each of apple and kohlrabi per serving). Blanch the slices for 5 seconds in boiling water then refresh in iced water. Drain well.

Set the EGG for direct cooking without the convEGGtor at 650°F/345°C with a cast iron grid, flat side up.

Cook the fish for 4 minutes per side, then remove to rest for 4 minutes. Place the oysters in their shells onto the grid. Cook for 5 minutes then shuck open, reserving the juice.

Put 6 large dots of Oyster Cream into each of 4 bowls. Place 2 slices each of kohlrabi and apple and the kohlrabi leaves. Carefully fillet the grilled fish and remove the skin. Divide the fish between the 4 bowls and top each with a grilled oyster. Add another slice of apple and kohlrabi on top of the fish, then pour in a little of the Kohlrabi, Apple and Parsley Juice. Garnish with herbs and flowers. Serves 4



Custom Stainless Steel BBQ Tool Set

Great chefs demand the best tools, and this custom-designed hardworking set offers every grilling enthusiast the ultimate equipment to handle every cookout! Extra long stainless steel shafts keep heat safely at a distance, and contoured handles provide a comfortable and secure grip. Great gift idea too!



High Carbon Stainless Steel Knife Set

The set of two high-quality knives includes a 3.5 in / 9 cm Paring Knife and an 8 in / 20 cm Chef Knife. High carbon stainless steel for years of trouble-free performance.



Premium Forged Stainless Steel Knife Set

The set of two custom knives includes an 8 in / 20 cm Chef Knife and a 3.5 in / 9 cm Paring Knife. Both are fully forged from one piece of high carbon German stainless steel from heel to tip.



Photo courtesy of David DeStefano

MICHELE FORGIONE

DEPTH OF FLAVOR

Often, our dishes include only three to four simple ingredients. And then, there's the simplicity of the EGG, which is the real 'secret ingredient'!

For more than 30 years, Michele Forgione has focused on the most basic of ingredients in his cooking. As a young boy, he and his brother made cavatelli after school – flour, water and their hands were the only requirements.

Today, as chef and co-owner of Montreal restaurants Impasto, Pizzeria Gema and Chez Tousignant, Forgione is still focused on the basics: fire, water – “good hydration is absolutely essential for the best pizza dough,” he says – and fresh local ingredients. For his bread and pizza dough, Forgione uses Quebec-grown flour and made-in-his kitchen sausages and pepperoni. At Chez Tousignant, the hot dogs and hamburgers are made from meat ground in-house; the buns also are made in-house. At Impasto, which is more of a fine dining Italian experience, simple dishes such as locally sourced radicchio with olive oil, salt and pepper, and octopus, which are first braised then given a hard sear on the EGG, are featured.

“We use what’s in season and let it really shine,” says Forgione. “Often, our dishes include only three to four simple ingredients. And then there’s the simplicity of the EGG, which is the real ‘secret ingredient’ for us.”

Forgione had heard about the EGG for a number of years before he got one about three years ago. “We chefs love our tools, and I heard through the chef grapevine that others were in love with it. In addition, my business partner had one at home, so I decided to start testing recipes on his. I was sold immediately. We now use it daily at Impasto, for meats, vegetables, appetizers. We don’t use a lot of garlic, which most people assume is required in Italian food, because the garlic can be overwhelming to the food’s natural flavor. Often, customers will ask, ‘Wow, what did you do to this?’ For many dishes, it’s simply salt, pepper and the flavor from the EGG.”

Forgione’s family roots in the Campagna area of Italy have influenced his long career as a chef. “My family made everything from scratch, including our cheese. My grandfather often said that you can be happy just eating a piece of good bread. And yes, we even do killer bread on the EGG. The aroma of bread that we all love is intensified by cooking it on the EGG.”

Forgione loves that the EGG retains its heat so well. “It’s basic in its own way – heat on the bottom and a dome on the top. We have an open kitchen and our customers are fascinated by watching us cook on the EGG. It’s certainly a focal point at Impasto.”



Grilled Pineapple with Mascarpone and Pistachio

“Depth of flavor” is what the EGG adds to cooking, according to Michele Forgione. “For this recipe, focus on the amazing aroma of the pineapple being grilled – it only lasts for a minute! The wonderful flavor is enhanced by just a bit of honey, orange juice and the Big Green Egg. Sublime!”

Ingredients

¼ cup (60 ml) honey, divided
¼ cup (60 ml) fresh orange juice
1 pineapple, peeled, cored and cut into planks
Big Green Egg wooden skewers, soaked in water for 30 minutes
1 pint (475 ml) mascarpone
¼ cup (60 ml) chopped pistachios

Method

Set the EGG for direct cooking without the convEGGtor at 350°F/177°C.

Whisk together 3 tablespoons honey and the orange juice in a small bowl. Brush the honey-orange mixture generously over the pineapple. Grill until just starting to caramelize, about 30 seconds. Flip and repeat for the other side. Transfer to a serving plate and drizzle the remaining honey over the top. Dollop with mascarpone and sprinkle with chopped pistachios.

This set of four high-quality stainless steel measuring cups features capacities marked in U.S and metric.



The Big Green Egg is widely known as The Ultimate Cooking Experience by legions of backyard cooks and grilling aficionados, and is quickly becoming an invaluable “tool of the trade” for top chefs in some of the most acclaimed restaurants around the world.

Many award-winning chefs are expanding their menus and enhancing their customers’ culinary experiences by adding the unique versatility of the Big Green Egg to their lineup ... and in many cases, their EGGs are prominently positioned in the main kitchen as a perfect companion to their commercial cooktops!

We are proud to highlight a few of our Culinary Partners. Check the full list at BigGreenEgg.com/culinarypartners and make plans to experience their creations yourself!

Select Culinary Partners from around the world

La Colombe Restaurant
Silvermist Wine Estate, Cape Town, South Africa

Chef René Brienen, Brienen aan de Maas
Well, Netherlands

Chef Golan Israeli, Dan Accadia Hotel,
Herzliya, Israel

Chef Tom Griffith, FLANK
Old Spitalfields Market, London, England

Chef Matthew Basford, Canoe
Atlanta, Georgia

Chef Thomas Bühner, Gourmet-Restaurant la vie
Osnabrück, Germany

Champêtre County
St-Denis, Saskatchewan, Canada

Chef Clayton Wells, Automata
Chippendale, New South Wales, Australia

Chef Jeremiah Bacon, The Macintosh
Charleston, South Carolina

Chef Robin Gill, Paradise Garage
London, England

Chef Peter Goossens, Restaurant Hof van Cleve
Kruishoutem, Belgium

The Big Green Egg Culinary Center



Tips and techniques



Hands-on and demonstration



Corporate team building



Themed classes and events

SPARK YOUR CULINARY CREATIVITY!

From novice cooks to grilling EGGsperts, the impressive new Big Green Egg Culinary Center, located on the campus of the corporate headquarters in Atlanta, will expand your culinary knowledge and entice you with new recipes, techniques, ingredients and skills that you can easily use with your own EGG.

The Big Green Egg Culinary Center offers cooking experiences that are engaging and fun ... everybody joins together for an interactive culinary event and then celebrates with an incredible EGG meal!

Our experienced culinary staff, expert instructors and guest chefs will guide you through a variety of exciting and interactive classes, including:

- *EGG 101, covering all of the basics for new EGG owners*
- *Hands-on and demonstration classes featuring a variety of culinary favorites*
- *Celebrity chef events and cookbook signings*
- *Themed classes, from holiday meals to tailgating tips*
- *Tips and techniques, including plank cooking, baking and special recipes*
- *Corporate team building and business events*
- *Private events and socials*



- Culinary Center
- History of the Big Green Egg Museum
- Retail Showroom

3786 DeKalb Technology Parkway
Atlanta, Georgia 30340



Learn More

Scan the QR or visit BigGreenEgg.com/culinary-center to see the full schedule of classes, to join our mailing list or to find a list of the many Big Green Egg Dealers who also offer cooking classes.

Big Green Egg® PRODUCT CATALOGUE



Please Note: The products shown in this catalogue are representative of various items that Big Green Egg makes available throughout the year – not all dealers stock every item, so if you cannot locate an item please contact Big Green Egg Customer Service for assistance.

Big Green Egg®



XXL XLARGE

- Grid Diameter: 29 in / 74 cm
- Cooking Area: 672 sq in / 4336 sq cm
- Weight: 424 lbs / 192 kgs

XL XLARGE

- Grid Diameter: 24 in / 61 cm
- Cooking Area: 452 sq in / 2919 sq cm
- Weight: 219 lbs / 99 kgs

L LARGE

- Grid Diameter: 18.25 in / 46 cm
- Cooking Area: 262 sq in / 1688 sq cm
- Weight: 162 lbs / 73 kgs

M MEDIUM

- Grid Diameter: 15 in / 38 cm
- Cooking Area: 177 sq in / 1140 sq cm
- Weight: 114 lbs / 52 kgs

> The Big Green Egg stands alone as **the most versatile barbecue and outdoor cooking product on the market**, with more capabilities than all other conventional cookers combined. From appetizers to entrees to desserts, the Big Green Egg will exceed all your expectations for culinary perfection ... and with seven convenient sizes to choose from, there is a Big Green Egg to fit any need and lifestyle!

XXLARGE

The Biggest Green Egg of them all, the unrivaled XXLLarge can easily handle your family reunion or cookouts with large groups – and is more than large enough to satisfy restaurant and catering needs. You'll need to gather a crowd to tackle all of the ribs, steaks and burgers this EGG can handle ... all at once! You can even roast a suckling pig ... explore all the culinary possibilities with the ultimate XXL!

XLARGE

The hardworking XLarge EGG provides a cooking area that can easily accommodate meals for large families and cookouts with all your friends – and you can efficiently prepare several meals over the coals at once. Ready to serve up twelve racks of ribs, twenty-four burgers or a couple of holiday turkeys with all the trimmings? No problem!

LARGE

The Large EGG is the most popular size and a favorite to handle the cooking needs of most families and gatherings of friends. Accommodates a complete array of EGGcessories for grilling, baking, roasting or smoking – and is versatile enough for weekend cookouts and pizza parties, large enough for eight steaks at once, and efficient enough for an impromptu meatloaf dinner for two!



LEARN MORE ABOUT EGG SIZES



S SMALL

- Grid Diameter: 13 in / 33 cm
- Cooking Area: 133 sq in / 856 sq cm
- Weight: 80 lbs / 36 kgs



MX MINIMAX

- Grid Diameter: 13 in / 33 cm
- Cooking Area: 133 sq in / 856 sq cm
- Weight: 76 lbs / 35 kgs



MN MINI

- Grid Diameter: 10 in / 25 cm
- Cooking Area: 79 sq in / 507 sq cm
- Weight: 39 lbs / 18 kgs

MEDIUM

Big flavor in a compact package! The Medium EGG is perfectly sized for smaller families and couples, and accommodates all the most popular EGGcessories. Get the famous Big Green Egg versatility and efficiency with plenty of cooking area to handle a backyard cookout of four large steaks or two whole chickens.

SMALL

The Small EGG is a great fit for smaller patios and balconies, and is often used as an addition to a larger EGG to allow the preparation of several courses at once. It's perfect for restaurants seeking the performance of an EGG in a size to fit a commercial kitchen.

MINIMAX™

A popular backyard staple and an invaluable culinary tool for restaurant chefs, the MiniMaxEGG® is designed with the height of a Mini yet all the volume capabilities of a Small. MiniMax comes with an easy to grip Carrier, so it's perfect as a table-side cooker at your garden party or a traveling EGG for motorhomes or tailgating.

MINI

A Mini EGG is the perfect portable solution for picnics and occasions when you want to take The Ultimate Cooking Experience with you! It is also a popular size for grilling on apartment balconies, vacations, boating and campfire meals – as well as a popular fixture in many commercial kitchens. Big results in a Mini package!



100% Natural Oak and Hickory Lump Charcoal

Our superior natural lump charcoal is made from 100% oak and hickory wood and contains no by-products, chemical fillers or petroleum additives. Natural lump charcoal imparts a great flavor to foods with no chemical aftertaste ... you will see – and taste – the difference immediately.

Natural Lump Charcoal

20 lb / 9 kg bag – 390011

Natural Lump Charcoal

10 lb / 4.5 kg bag – 110503

Charcoal Starters

Lighting charcoal is a breeze with our three recommended starters.



SpeediLight® Natural Charcoal Starters

Our SpeediLight Natural Charcoal Starters light easily and are odorless and tasteless, with no chemical aromas or residue. Plus, they're clean, safe and ready to use without the need for any lighter fluid. Box of 24 squares – 101020



EGGniter® Electric Charcoal Igniter

This genuine Big Green Egg Electric charcoal igniter is quick, easy and convenient – the EGGniter ignites lump charcoal or hardwood in just minutes without striking a match ... by using only super-heated air! 120V/1500W – 117540



Electric Charcoal Starter

If you prefer ignition at the click of a finger, then switch on our Electric Starter. This handy device, with a heat resistant handle, will have you cooking in minutes without even striking a match! – 101013

Build your outdoor kitchen one step at a time with the Big Green Egg Modular Nest System!

Start with an EGG Frame, then add to your custom EGG display with Expansion Frames and a variety of beautiful and functional inserts. You won't believe all of the possibilities!

EGG Frames

EGG Frames include one EGG Frame, stainless steel grid insert and tool hook. Levelers included, optional casters available.

For XLarge EGG – 120229
For Large EGG – 120212



120212



Modular Nest Inserts

Distressed Acacia Wood Insert – 120267
Acacia Wood Insert – 120250

Solid Stainless Steel Insert – 120274
Stainless Steel Grid Insert – 120243



Expansion Frame

Includes one Connector Pack to secure the Expansion Frame to the EGG Frame. Add a combination of beautiful inserts to customize your outdoor cooking area – 120236



BBQ Tool Hooks

Solid stainless steel hooks can be added to any side of the Modular Nest Frame. Also includes wood screws so you can add extra tool storage to any wooden table – 120281



120410



114662

Locking Caster Kits

For easy mobility, add a set of casters to your Big Green Egg Hardwood Table or Modular Nest.

4 in / 10 cm Caster Kit – 120410
Set of 2, with 1 locking caster

2 in / 5 cm Caster Kit – 114662
Set of 4, with 2 locking casters

**Designed and engineered to work perfectly with
your Big Green Egg for years of enjoyment!**

Custom Cooking Islands

The 76 in / 1.9 m Custom Cooking Island provides an impressive working surface and features high-quality aluminum and steel construction with solid stainless steel door pulls, a heavy-duty sliding shelf, paper towel rack, ample storage cabinets for charcoal and utensils, locking casters, a durable, weather resistant powder coated finish and comes with a lifetime warranty!

76 in / 1.9 m Cooking Island for Large – 116352
76 in / 1.9 m Cooking Island for XLarge – 116369



76 in / 1.9 m
Cooking Island



60 in / 1.5 m
Cooking Island



The 60 in / 1.5 m Custom Cooking Island fits smaller spaces yet offers the convenience of a heavy-duty sliding shelf and features the same high-quality aluminum and steel construction as the larger version.

60 in / 1.5 m Cooking Island for Large – 116338
60 in / 1.5 m Cooking Island for XLarge – 116345



- **XLarge Dimensions:**
61 in L x 32 in W x 31 in H
1.6 m L x .8 m W x .8 m H
- **Large Dimensions:**
60 in L x 25 in W x 31 in H
1.5 m L x .6 m W x .8 m H



Acacia hardwood table tops feature an attractive Big Green Egg logo

Acacia Hardwood Tables

Fashioned from exotic woods grown in ecologically sustainable forests, Big Green Egg's solid acacia tables are handcrafted to the highest quality standards and offer ample and convenient working and serving area. Each table is a durable and unique work of art so beautiful that you'll want to use them indoors!

Solid Acacia Table for Large – 118257
Solid Acacia Table for XLarge – 118264

Table Nest

The metal Table Nest, which provides air flow beneath the EGG, is an optional component for all Big Green Egg tables. The Table Nest is also useful for custom outdoor kitchens.

Please note that the Table Nest is not designed for free-standing applications unless the EGG is housed within a Table, Island or built-in surround.

- Table Nest for XXL – 115638
- Table Nest for XL – 113238
- Table Nest for L – 113214
- Table Nest for M – 113221



XXL Table Nest

See Safety Tips at BigGreenEgg.com. Do Not Place EGG directly on wood or combustible surface!
Table Nest must be used in conjunction with a table. Not for use as a free-standing support for your EGG.

NESTS, EGG MATES AND HANDLERS

Nests® and Carriers

The Big Green Egg Nests are designed to raise your EGG to a comfortable cooking height while allowing for easy mobility. Nests are made of durable powder-coated steel. XXLarge, XLarge, Large, Medium and Small Nests include two locking casters.

- Nest for XXLarge EGG – 114723
- Nest for XLarge EGG – 301079
- Nest for Large EGG – 301000
- Nest for Medium EGG – 302007
- Nest for Small EGG – 301062
- Carrier for Mini EGG – 116451

The MiniMax EGG comes complete with its own transportation in the form of a sturdy, easy to grip Carrier.



Portable Nest for MiniMax EGG

The Portable Nest for the MiniMax is designed to raise this portable EGG to a comfortable cooking height – perfect for camping, tailgating or wherever your next pop-up event happens. The Portable Nest conveniently folds for storage or transporting to events – 120649



Folding EGG Mates®

The Big Green Egg Mates are used with an EGG in a Nest and provide convenient working or serving space. The set of two Mates can be folded down when not in use.

Wooden EGG Mates

EGG Mates for XLarge EGG – 301048

EGG Mates for Large EGG – 301031

EGG Mates for Medium EGG – 301055

EGG Mates for Small EGG – 114563

Durable Composite EGG Mates

Easy to clean composite Mates feature a non-slip textured surface, a wider side profile, subtle wood-grain detailing and attractive BGE logo.

3-Slat Composite Mates

For XXLarge EGG – 115454
For XLarge EGG – 115447
For Large EGG – 115430

2-Slat Composite Mates

For Medium EGG – 115416



WOODEN

COMPOSITE



EGGmat

Enhance and protect the area around your EGG with the heat and stain-resistant EGGmat. The heat-resistant pad is constructed from eco-friendly recycled materials and features a prominent Big Green Egg logo. Engineered for durability, the EGGmat is stain, fading and mildew-resistant. 30 in x 42 in (76 cm x 107 cm) – 117502



IntEGGrated Nest+Handler

The IntEGGrated Nest+Handler merges two great products (EGG Nest and Nest Handler) for a strong, stable, mobile base for the EGG. Includes 2 locking casters.

For Large EGG – 120175

Nest Handlers

The Big Green Egg Nest Handlers secure the EGG to the Nest to ensure greater stability and easier handling when rolling. The Handlers are made of durable powder-coated steel.

For XXLarge EGG – 114730

For XLarge EGG – 302083

For Large EGG – 301086

For Medium EGG – 302076



EGG COVERS

Our Big Green Egg covers are made from a ventilated, heavy-duty material and feature the Big Green Egg logo and coordinating piping. The weatherproof fabric protects against fading from UV rays, and moving the cover off and on is easy with the convenient handle.



Premium Weatherproof Table Covers

For XLarge EGG in a Big Green Egg Wood Table – 117182
For Large EGG in a Big Green Egg Wood Table – 117175



Premium Weatherproof Nest Covers

The Nest covers fit all configurations of the EGG – with or without Mates or Handler.

For XXLarge EGG – 117007
For XLarge EGG – 116994
For Large EGG – 116987
For Medium EGG – 116970
For Small EGG – 116963
For MiniMax EGG – 116956
For Mini EGG – 116949



Dome Covers For Modular Nests or Built-In Outdoor Kitchens

For XLarge EGG – 116932
For Large EGG – 116925

Premium Weatherproof Island Covers

For XLarge or Large EGGs in a 76 in / 1.9 m Cooking Island – 117199

For XLarge or Large EGGs in a 60 in / 1.5 m Cooking Island – 116918



KNOW THE HEAT

Digital Thermometers

The digital thermometer is a necessity when cooking meat or poultry to safely monitor the internal temperature.



Quick Read Digital Food Thermometer

Small, convenient digital thermometer fits in your pocket – 101044



Dual Probe Wireless Remote Thermometer

This remote wireless thermometer monitors temperatures from a distance of up to 300ft / 91m. Includes preset temperatures for beef, veal, lamb, pork and poultry ... and nine popular game meats – 116383



Instant Read Digital Food Thermometer

Highest accuracy readout of the internal temperature of foods – 112002



Professional Grade Infrared Cooking Surface Thermometer

Safely measures the temperature of cooking surfaces without contact for precise heat control every time! Aim the precision laser light beam at pizza stones, griddles or cooking grids to instantly see the surface temperature before adding food to the grill. Measures surface temperatures in a range from 32°F to 800°F / 0°C to 427°C – 114839

SMOKING WOODS AND PLANKS



Smoking Wood Chips and Chunks

Wood smoking chips and chunks add a variety of delicious flavors to foods cooked over the coals. Each type of wood will impart a different flavor to meats or other foods, resulting in an endless variety of new flavor combinations.



Apple Chips and Chunks provide a natural sweetness that's mild enough to use with fish, shellfish and poultry – 113962 (Chips), 114617 (Chunks)

Cherry Chips add a mild and slightly fruity flavoring and pair well with game birds and almost any meat including beef tenderloin, pork, poultry and lamb – 113979 (Chips)

Hickory Chips and Chunks enhance any red meat such as brisket or pork shoulder, as well as turkey and chicken – 113986 (Chips), 114624 (Chunks)

Mesquite Chunks add a tangy smoke flavor and are best suited for large cuts of beef such as brisket – 114631 (Chunks)

Pecan Chips add a rich, mellow flavor to chicken and fish, and gives poultry a golden brown skin that enhances any holiday feast – 113993 (Chips)

Jack Daniel's® Barrel Chips are a good choice for flavoring steak, veal, pork and poultry – 017499 (Chips)



Planked Brie with Cranberry Relish

Ingredients

Cranberry Relish

1½ cups (360 ml) granulated sugar
½ cup (120 ml) cranberry juice
½ tsp (3 ml) freshly grated ginger
½ tsp (3 ml) ground cinnamon
16 oz (450 g) bag fresh cranberries
Zest of 1 orange (orange part only)

Brie

1 5-in (13 cm) wheel of Brie
1 orange, sliced into thin rounds
1 Western Cedar Grilling Plank
White wine for soaking the plank

Method

Set the EGG for direct cooking without the convEGGtor at 375°F/190°C.

to the syrup and cook just until they begin to pop, about 2-3 minutes. Skim the foam off the surface with a metal spoon and discard. Remove from heat, stir in orange zest and cool to room temperature, uncovered. Cover and store in the fridge for up to 3 months.

Brie

Soak the cedar plank in white wine and water for 30 minutes. Place the plank logo-side down for 3 minutes. Flip the plank; place the orange rounds on the plank then add the brie on top. Smoke for 15-18 minutes, remove from the EGG and top with ½ cup (120 ml) Cranberry Relish. Serve with crackers or toasted crostini.

Cranberry Relish

In a Cast Iron Skillet, add sugar, juice and spices. Cook, stirring often, until sugar dissolves, syrup is clear and comes to a rolling boil. Add cranberries

Gourmet Grilling Planks

Plank cooking is a unique culinary method which originated with the Native Americans, and has evolved into a popular at-home cooking technique that adds a new dimension of flavor to your grilling experience. Our planks come from certified sustainable wood sources; two planks per package. 5 in x 11 in (13 cm x 28 cm)

Western Red Cedar Grilling Planks

offer a robust, woody flavor to fish, beef and other grilling favorites – 116307

Northwest Alder Grilling Planks

impart a subtle, smoky finish to fish, chicken and vegetables – 116291



Scan to view the Big Green Egg Plank Cooking Publication

CERAMIC EGGCESSORIES

The Big Green Egg Pizza & Baking Stone is a versatile piece of cookware for baking a variety of recipes from pizzas to breads to desserts. The stone distributes heat for even baking and browning, and the ceramics pull moisture from the outer surface of the dough for brick-oven crustiness. The stone also retains heat, so foods remain warm longer.



The convEGGtor®



The convEGGtor is designed to facilitate indirect cooking on the Big Green Egg by providing a heat-directing barrier between the food and the charcoal, transforming your EGG into an outdoor convection oven. The design of the convEGGtor, in conjunction with the thermal properties of the EGG, allows heat to efficiently radiate within the dome and prevents the direct flames from reaching the food.

For XXLarge EGG – 114419
 For XLarge EGG – 401052
 For Large EGG – 401021
 For Medium EGG – 401038
 For Small EGG – 401045
 For MiniMax EGG – 116604
 For Mini EGG – 114341



Ceramic Pizza & Baking Stones

Pizza & Baking Stones
 Fits XXLarge and XLarge EGGs
 Diameter 21 in / 53 cm – 401274

Fits XXLarge, XLarge and Large EGGs
 Diameter 14 in / 36 cm – 401014

Fits XXLarge, XLarge, Large, Medium, Small and MiniMax EGGs
 Diameter 12 in / 30 cm – 401007



Deep Dish Pizza & Baking Stone
 Ideally suited for baking pizza, pies, quiche ... even brownies or cinnamon rolls.

Fits XXLarge, XLarge and Large EGGs
 Diameter 14 in x 2 in depth (36 cm x 5 cm)
 – 112750

The Pizza & Baking Stone turns your EGG into a fire-brick oven, perfect for making pizzas, breads, desserts and other baked items.

With the Half Moon Baking Stone, you can cook indirect on one half of the cooking grid, while keeping the other half of the grid available for roasting meats or vegetables.

Half Moon Baking Stones
 Fits XXLarge and XLarge EGGs
 Diameter 21 in / 53 cm – 002389

Fits XXLarge, XLarge and Large EGGs
 Diameter 16 in / 41 cm – 002396

PIZZA AND BAKING TOOLS

With the Big Green Egg and our pizza EGGcessories, you can easily bake your own international specialties ... custom flatbreads, pizzas, calzones, tortillas or naan.



Dough Rolling Mat

Easily roll out and perfectly form pizza, calzone or bread dough at home just like a professional pizzaiolo! Our flexible silicone mat provides a large, slip-proof surface with guidelines for making five sizes of crust. The mat is also perfect for rolling pie crusts, cookie dough or other pastries. Easy recipe included on mat – 114167



Gather your favorite ingredients and toppings – along with your family and friends – and enjoy creative, hot-off-the-EGG homemade meals!



Aluminum Pizza Peel

Features a smooth and sturdy aluminum surface with a comfortable Soft Grip handle. Keeps hands away from the heat and provides a convenient way to handle pizza, calzones and bread – 118967



Calzone Press

Spice up your next pizza night! Use a Calzone Press to create custom calzones and filled pastries at home with everyone's favorite ingredients. Works well with your favorite pizza or pie dough. Easy recipe included.

Family Size Calzone Press – 114181

Personal Size Calzone Press – 114174





Rustic Peach and Thyme Galette with Almonds and Honey Yogurt

Recipe adapted from **Dishing Up the Dirt: Simple Recipes for Cooking Through the Seasons**, published by HarperCollins Publishers.

Ingredients

1½ lbs (680 g) small ripe peaches, peels left on, quartered and pitted
 ¼ cup + 4 tbsp (120 ml) honey, divided
 ⅓ cup (160 ml) almonds
 1 cup (240 ml) all-purpose flour
 ¼ cup (60 ml) sugar
 ½ tsp (3 ml) fine sea salt
 7 tbsp (105 ml) chilled, unsalted butter cut into ½ in chunks
 1 egg, separated
 3 tbsp (45 ml) fresh thyme leaves
 1½ cups (360 ml) plain yogurt

Method

Set the EGG for indirect cooking with the convEGGtor at 400°F/204°C.

Prepare the filling: Cut three sheets of parchment paper slightly smaller than the size of a Baking Stone and lay one on the stone. Arrange the peaches, skin side down, on the parchment; drizzle with honey. Roast until the peaches are tender and beginning to brown, about 20 minutes. Flip the peaches, then continue roasting until they are very tender, about 12 more minutes. Set the Baking Stone and the peaches aside to cool.

Make the crust: Coarsely chop the almonds in a food processor; transfer to a bowl. Add the flour, sugar and salt to the processor and pulse a few times. Add the butter and pulse until the mixture resembles a coarse meal. Add the egg yolk and blend until moist clumps form. Gather the dough into a ball and flatten it into a disk. Wrap it in plastic and freeze for at least 30 minutes. Let the dough stand at room temperature for 10 to 15 minutes before rolling out.

Roll out the dough disk in between the two remaining floured sheets of parchment to a 10 inch (25 cm) round. Remove the top sheet of parchment and set it aside. Sprinkle the dough evenly with ½ of the chopped almonds. Replace the parchment atop the crust and roll it to an 11 inch (28 cm) round, embedding the nuts in the dough.

Reduce the temperature of the EGG to 375°F/191°C. Invert the crust and parchment onto a Baking Stone, nut side down. Remove the parchment that is now on top and arrange the peaches over the center, alternating skin up and skin down; leaving a 1½ to 2 inch (4 to 5 cm) border. Using the parchment as an aid, fold the outer edge of the crust over the peaches. Sprinkle the crust with the thyme and 2 tablespoons honey and the remainder of the chopped almonds. Brush the egg white over the crust. Add the Stone to the EGG and bake until the crust is golden brown, about 30 minutes, cool for 20 minutes.

Mix the yogurt and honey. Cut the galette into wedges and serve with the honey yogurt.

The Ultimate Pizza Wheel

Features a durable stainless steel rotary blade for perfect slices and a non-slip grip and integrated blade guard for safety. The cutter disassembles for easy cleaning in the dishwasher – 118974



Pizza Slice Server

Serve up your creations like a pro. The extra-wide stainless steel blade is ideal for easy handling of galettes, pizza, pie, appetizers and more. Oversized soft grip handle for comfort and control – 114143



SPECIALTY COOKWARE

Cast Iron Plancha Griddles

The Dual-Sided Cast Iron Plancha Griddles are ideal for searing meats and seafood, sautéing vegetables and grilling sandwiches. Authentic, high temperature “steak house” grilling is quick, easy and delicious.

Round Plancha Griddles

14 in / 36 cm, fits XXL, XL, L – 117656

10.5 in / 27 cm, fits XXL,
XL, L, M, S, MX – 120137



Half Moon Plancha Griddles

22 in / 56 cm, fits XXL, XL
– 116406

16 in / 41 cm, fits XXL,
XL, L – 104090



Below: the 10.5 in / 27 cm Plancha Griddle (120137) is designed to pair with the 10.5 in / 27 cm Cast Iron Skillet (120144) to form a Dutch oven.



Cast Iron Skillet

Perfect for searing, braising, baking, sautéing or roasting. The pre-seasoned skillet is designed with two easy to grip handles and built to deliver a lifetime of cooking enjoyment!

14 in / 36 cm, fits XXL, XL, L – 118233

10.5 in / 27 cm, fits XXL, XL, L, M, S, MX – 120144



118233



5.5 quart / 5.2 liter
Oval - 117670

4.2 quart / 4 liter
Round - 117045

Enameled Cast Iron Dutch Ovens

The Enameled Cast Iron Dutch Ovens provide excellent heat retention, making them ideal for slow-cooking, braising, roasting, simmering and baking! With lids that double as an additional cook pot, the durable enameled Dutch Ovens are easy to clean, dishwasher safe and heat-resistant to 450°F / 232°C. Fits XXL, XL and L EGGs.



Sausage-Stuffed Onions

Ingredients

8 small onions (a mix of red and white), peeled
1 tbsp (15 ml) olive oil
1¼ lb (570 g) spicy pork sausage
5 cloves garlic, minced, divided
½ tsp (2.5 ml) kosher salt
1 tsp (5 ml) ground black pepper
1 tsp (5 ml) dried oregano
½ tsp (2.5 ml) crushed red pepper
⅓ cup (80 ml) grated Parmigiano Reggiano cheese
¼ cup (60 ml) panko
¼ cup (60 ml) butter, melted
1 cup (240 ml) beef broth
3 shallots, cut into chunks
2 sprigs fresh thyme

Method

Set the EGG for direct cooking at 375°F/191°C.

Add 2 quarts (1.9 L) water to a Dutch oven and place on the cooking grid. When the water comes to a boil, add the onions and cook for about 15 minutes until tender; remove from the water and cool. Cut off the tops and hollow out the onions, leaving 2 outer layers intact. Finely chop ½ cup of the scooped out centers.

In a Cast Iron Skillet, heat the oil. Add the chopped onion and cook until translucent. Add sausage, 2 cloves garlic, salt, ½ tsp black pepper, oregano and red pepper. Cook until browned; remove from the skillet and wipe the skillet with a paper towel. In a bowl, combine the cheese, panko, remaining black pepper and oregano; stir in melted butter.

In the skillet, combine the broth, wine, shallots, remaining garlic and 1 sprig thyme. Spoon the sausage mixture into hollowed-out onions and add to the skillet. Bake for 20 minutes then sprinkle with the panko/cheese mixture. Bake for an additional 20 minutes until the topping is golden brown. Garnish with thyme and serve.





Cast Iron Cooking Grids

For perfect sear marks on your food, utilize the superior heat conductivity of the Cast Iron Cooking Grid. The cast iron gets very hot and retains heat, turning it into a perfect searing surface.

for Large EGG – 100092
 for Medium EGG – 100085
 for Small or MiniMax EGG – 100078
 for Mini EGG – 113870



Half Moon Cast Iron Grid for XLarge EGG – 103048



Cast Iron Dutch Oven

The 5.5 quart / 5.2 liter Dutch Oven is ideal for cooking stews, soups, chili and even cobblers. Fits XXLarge, XLarge, Large and Medium EGGs – 117052



Multi-Level Tiered Racks

When you are cooking several different foods at once or when preparing meals for a large crowd, our assortment of multi-level grids increases the amount of cooking space in your EGG.



2 Level Cooking Grid
 Chrome-plated steel base with a porcelain coated grid. Fits XXLarge and XLarge EGGs – 201317

3 Level Cooking Grid

The top levels of the rack rotate and are adjustable to multiple levels. Disassembles for easy storage. Dishwasher safe. Fits Large EGG – 370006



Folding Grill Extender
 Easily attaches to your cooking grid to add a second level of cooking surface in your EGG. The grid folds up to allow for larger dishes, such as roasts or whole chickens and conveniently folds flat for storage. Fits XLarge and Large EGGs – 201126

Raised Grids

The Half Moon Raised Grids with Drip Pan give you the flexibility to cook direct on one half of the EGG and indirect on the other half. The Raised Grids can be paired with an optional Half Moon Baking Stone.

Half Moon Raised Grid with Drip Pan

fits XXLarge and XLarge EGGs – 101082
 fits XXLarge, XLarge and Large EGGs – 101051

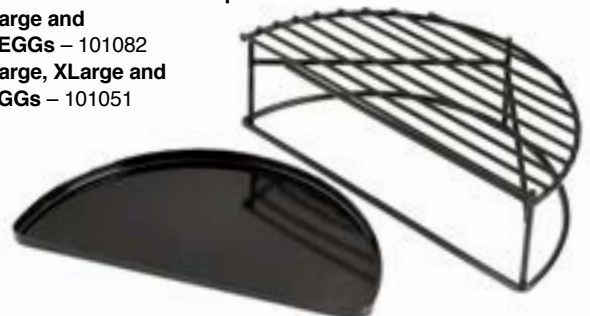



Rib and Roast Racks

Our dual purpose Rib and Roast Racks can be used upright to hold roasts and poultry or can be flipped over to serve as an efficient rib rack.

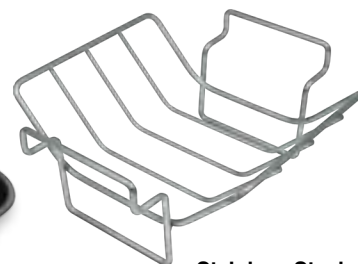

**Stainless Steel
Small Rib and Roast Rack
Fits XXLarge, XLarge, Large, Medium
and Small EGGs – 117557**

Anodized Aluminum Roasting & Drip Pans

The Roasting & Drip Pans feature an easy to clean surface and have the Big Green Egg logo embossed in the bottom of the pan. The Rectangular Drip Pan works perfectly with the Rib and Roast Rack for cooking turkey, roasts, chickens and other larger cuts of meat. The Round Drip Pan works well with the Vertical Roasters.



Rectangular Drip Pan

13 in x 9 in / 33 cm x 23 cm,
fits XXLarge, XLarge, Large
and Medium EGGs – 117397

Round Drip Pan

Diameter 9 in / 23 cm, fits XXLarge,
XLarge, Large, Medium, Small
and MiniMax EGGs – 117403

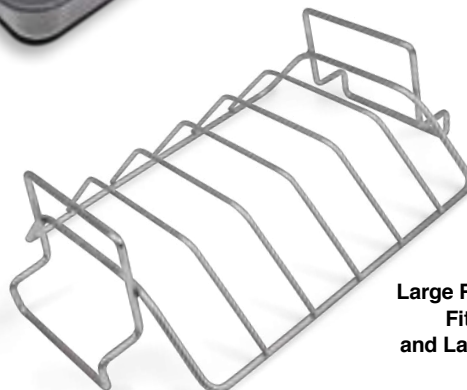

**Stainless Steel
Large Rib and Roast Rack
Fits XXLarge, XLarge
and Large EGGs – 117564**

Perforated Grids

The perforated grids allow heat and flavor to reach the food and make it easy to cook fish or small foods like mushrooms, asparagus, shrimp or scallops that might fall through the standard cooking grids. The half-moon grid leaves half of your cooking space available for direct heat.

Round Perforated Cooking Grids

Diameter 16 in / 41 cm, fits XXLarge, XLarge
and Large EGGs – 201287

Diameter 13 in / 33 cm, fits XXLarge, XLarge, Large,
Medium, Small and MiniMax EGGs – 102010

Half Moon Perforated Cooking Grids

Diameter 23 in / 58 cm, fits XXLarge
and XLarge EGGs – 116390

Diameter 16 in / 41 cm, fits XXLarge,
XLarge and Large EGGs – 106056





Perforated Grill Wok

A Grill Wok makes it easy to cook vegetables, meat, seafood or any other smaller pieces of food that might slip through the standard cooking grids. The Grill Wok allows the heat and smoke to circulate around the foods for even cooking and flavor absorption.

Fits XXLarge, XLarge, Large, Medium, Small and MiniMax EGGs – 002068



Stir-Fry & Paella Grill Pan

This 4 quart / 3.8 liter pan is perfect for creating traditional paella recipes as well as delicious stir-fry meals! Experiment with different meats, poultry, seafood and seasonal vegetables to create your favorite interpretations of these popular international dishes. **Fits XXLarge, XLarge and Large EGGs – 002167**



Mini Burger "Slider" Basket

Holds up to twelve delicious mini-burgers or sliders, which are fun and easy to top with cheese or other creative toppings. **Fits XXLarge, XLarge and Large EGGs – 002105**

Vertical Poultry Roasters

Using a vertical roaster on the EGG will produce the juiciest, most flavorful poultry you've ever tasted! Vertical roasters hold a chicken or turkey upright during cooking for even browning and easier carving when done. The ceramic and folding roasters hold liquid such as fruit juice or beer to add flavor to the poultry.



Folding Stainless Steel Beer Can Chicken Roaster
Fits XXLarge, XLarge, Large, Medium and Small EGGs – 002099

Stainless Steel Vertical Chicken Roaster
Fits XXLarge, XLarge, Large, Medium and Small EGGs – 117458

Stainless Steel Vertical Turkey Roaster
Fits XXLarge, XLarge, Large and Medium EGGs – 117441

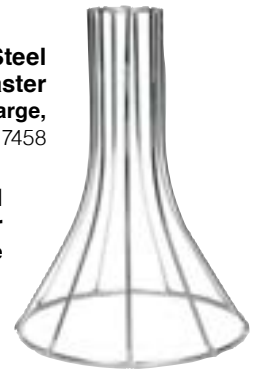

Ceramic Vertical Chicken Roaster
Fits XXLarge, XLarge, Large, Medium and Small EGGs – 119612



Vertical Turkey Roaster
Fits XXLarge, XLarge, Large and Medium EGGs – 119629

GRILLING TOOLS



Solid Teak Cutting Board

Made of sustainably harvested plantation teak, the most stable wood for outdoor or wet applications. This board is both beautiful and functional ... built for outdoor use beside the EGG, perfect for carving grilled meats and vegetables, and attractive as a serving board for all of your favorite grilled foods – 120632



All Purpose Cutting Board

Features a drip channel on one side for collecting juices from vegetables and meats, and a flat surface on the reverse side for more cutting space. Non-slip silicone border keeps the board from sliding for easy cutting, slicing and chopping – 117069



Comfort Tie® Grilling and Kitchen Apron

Grill in style with this EGGstra comfortable apron! The comfortable, one-size design features unique Comfort-Tie elastic ties that hold the apron securely in place. Features handy front pockets and an attractive Big Green Egg logo. Neck strap easily adjusts for comfort and height – 117113

Stainless Steel Kitchen Shears

Big Green Egg Kitchen Shears are ideal for a multitude of tasks, from trimming poultry, meats and seafood to cutting pizza and snipping herbs, flowers and vegetables. The shears feature ergonomic, textured handles for a secure grip, and lock for safe storage. Dishwasher safe. 9 in / 23 cm – 120106



100% Cotton All-Purpose Towels

Crafted from top quality waffle-weave cotton, these soft and absorbent towels look great and also make cleaning up a breeze. You'll use these plush, lint-free towels for everything from polishing glassware to barbecue spills. The perfect gift for your favorite EGGhead! Embroidered logo, 3 pack – 116840



EGGmitt® BBQ Glove

The EGGmitt BBQ Glove is made of aramid fibers, also used in aerospace, to form a barrier preventing heat from entering the soft cotton inner layer. Extra long cuff for ultimate protection. The Mitt has silicone on the surface for superior grip and is reversible for the left or right hand – 117090



Super-Flexible, Heat-Resistant Silicone BBQ Mitt

This super-flexible mitt withstands extreme heat up to 450°F/232°C. Features a soft, comfortable lining and an FDA-approved, BPA-free silicone exterior – 117083



**Premium Forged
Stainless Steel Knife Set**

The set of two custom Ergo Chef® knives includes an 8 in / 20 cm Chef Knife and a 3.5 in / 9 cm Paring Knife. Both are fully forged from one piece of high carbon German stainless steel from heel to tip – 113207



**Custom Big Green Egg
Stainless Steel Knife Set**

The set of two high-quality knives includes a 3.5 in / 9 cm Paring Knife and an 8 in / 20 cm Chef Knife. High carbon stainless steel for years of trouble-free performance – 117687

All Natural, Eco-Friendly Bamboo Skewers



These 10 in/25 cm all natural skewers are perfect for grilling and serving kabobs or chunks of chicken, shrimp or vegetables. Each skewer has a Big Green Egg logo on an easy-grip handle. 25 skewers per pack – 117465

Flexible Skewers

Marinating is easy with flexible 100% food-grade stainless steel skewers that allow you to marinate in bags and then transfer to the EGG without handling the food twice. The pointed ends stay cool and allow you to easily turn or remove food from the EGG – 201348



Silicone-Tipped BBQ Tongs

These stainless steel BBQ Tongs are perfect for turning grilled foods, sautéing vegetables, serving pasta and tossing salads. The silicone-tipped tongs are heat resistant up to 500°F/260°C.

12 inch (30 cm) – 116857
16 inch (40 cm) – 116864



Custom Stainless Steel BBQ Tool Set

Great chefs demand the best tools, and this custom-designed hardworking set offers every grilling enthusiast the ultimate equipment to handle every cookout! Extra long stainless steel shafts keep heat safely at a distance, and contoured handles provide a comfortable and secure grip. Great gift idea too!

Set of Three: BBQ Tongs, Grill Spatula and Basting Brush
(includes a replacement Brush head) – 116901

Stainless Steel Grill Spatula – 116888
Stainless Steel Grill Tongs – 116871
Stainless Steel Grill Brush – 116895



**Stainless Steel
Measuring Cups**

Set of four heavy-duty stainless steel measuring cups (1 cup, ½ cup, ⅓ cup, ¼ cup). Includes a stainless steel ring for easy storage; dishwasher safe – 119551

**Professional Grade
Stainless Steel Meat Claws**



These high-quality meat “claws” are designed for easy handling and shredding of larger pieces of meat such as roasts, turkey, chicken and pork. Expertly shred a smoked pork butt into pulled pork sandwiches in minutes for “professional chef” results! High-quality stainless steel with comfort grip handles – 114099



Professional Grade BBQ Tool Set

This 3-piece stainless steel barbecue tool set includes everything you need for your cookout! Stainless steel shafts keep heat safely at a distance, and solid wood handles provide a comfortable and secure grip.

Set of three: BBQ Tongs, Grill Spatula and Basting Brush – 117212

GRILLING TOOLS

Barbecue Sauce Mop

Use this all natural, washable cotton Barbecue Sauce Mop to easily add your favorite basting mixtures, flavored butters, glazes and barbecue sauce to anything cooked on an EGG! Removable brush head detaches for easy soaking and cleaning – 114105



Replacement Heads for Barbecue Sauce Mop

Set of two – 114297

Soft-Grip Corn Holders

Genuine Big Green Egg Corn Holders add convenience and a touch of fun every time you grill corn on the cob! High-quality stainless steel prongs and soft-grip handles hold corn securely and keep fingers cool and clean. Corn Holders are designed to nest together for safe storage. Contains 4 pair (8) holders – 117335



Stuff-A-Burger® Press

Stuff burgers with everyone's favorite ingredients – the combinations are endless! Fun and easy to use, the Stuff-A-Burger Press is perfect for any ground meat from juicy beef to mouthwatering chicken, turkey or lamb – makes great stuffed veggie burgers too! Adjustable to two sizes – 114082



Pigtail Food Flipper®

This innovative tool flips everything from a rack of ribs to steaks, tenderloins or chicken. The Pigtail's hook and shaft are made of surgical-grade stainless steel for strength and durability, and the hook will not leave marks in your meat or cause meats to bleed – 201515



Stainless Steel Flavor Injector

Add flavor and juiciness to any roast or poultry! Inject marinades, butter or other flavorings deep into meats to baste and tenderize from the inside out! Includes 2 needles; one for chunky marinades and one for liquids – 119537



Cast Iron Sauce Pot

This heavy-duty, Cast Iron Sauce Pot is perfect for melting butter or warming marinades or barbecue sauce. The no-mess basting brush conveniently nests into the pot handle, and the removable silicone brush head is dishwasher safe for easy cleanup! 2 cups / 480 ml – 117663

Stainless Steel Grill Rings

Now you can grill apples, onions, tomatoes and even artichokes with surprising ease and efficiency. Simply stuff the fruit or vegetable with your favorite seasoning, place on the spike and grill indirect. Set of 3 – 002280





Ash Removal Pan

Although natural lump charcoal produces little ash and requires minimal clean up, the task becomes even easier with the EGG Ash Pan – 106049



Heavy Duty Grid Lifter

The comfort grip Grid Lifter easily and safely grips and lifts stainless and cast iron cooking grids – 117205



V-Notch Grid Cleaner

(Left) The extended handle allows you to clean the grid even when the EGG is hot. The angled design makes cleaning the top and sides of the cooking grid a breeze – 201324



Dual Brush Grill and Pizza Stone Scrubber

Heavy duty, stainless steel mesh scrubber pads outperform wire brushes – with no bristles to come loose. The dual brush design works perfectly to easily remove baked-on remnants from your Pizza & Baking Stone – 119476



Stainless Steel Mesh Grill Scrubber

Stainless steel mesh outperforms wire grill brushes and the extra long handle keeps heat safely at a distance. Includes one stainless steel replacement scrubber pad – 119469



Replacement Grill Scrubber Heads

Quick and easy brush replacement; set of two replacement mesh scrubber pads – 119483

Grid Gripper

Easily and safely grips and lifts stainless cooking grids and grilling planks – 118370



Ash Tools

The perfect utensil for removing the small amount of ash that collects in the bottom of the EGG. Using the bar at the end of the Ash Tool, simply pull the ash out of the Draft Door.

Ash Tool for XLarge or XXLarge EGGs
– 119490

for Large or Medium EGGs
– 119506

for Small, MiniMax or Mini EGGs
– 301024



301024

119506

119490



The Big Green Egg Cookbook

The original 320-page, hardcover *Big Green Egg Cookbook* contains extensive color photography and more than 160 delicious recipes that maximize the unique cooking abilities of the EGG. *The Big Green Egg Cookbook* is the perfect inspiration for grilling enthusiasts everywhere ... and the ideal gift for your favorite EGGhead! – 079145



**Ray Lampe's
Big Green Egg Cookbook**

Big Green Egg Ambassador Ray "Dr. BBQ" Lampe has written the ultimate cookbook for EGGheads – packed with more than eighty great recipes covering all the diverse techniques that the versatile EGG can deliver!

Noted for classics like the NFL Gameday Cookbook and BBQ RoadTrip, Dr. BBQ now puts his spin on EGGing with page after page of mouth-watering recipes so appealing you will want to try them all! Makes a great gift for all outdoor cooks – 118073



**The Big Green Egg Book –
Inspiring Recipes from
Around the World!**

Take your cooking on the EGG to the next level with *The Big Green Egg Book*. Coffee table quality, with more than 50 recipes and profiles of 15 international chefs who use the Big Green Egg in their kitchens, this beautiful hard-bound (208 pages) cookbook is bursting with innovative ideas and creative recipes! – 116680

**Big Green Egg
EGGtoberfest® Cookbook**

Favorite recipes from the Big Green Egg EGGtoberfest, an annual event held in Atlanta, Georgia each fall. 112 pages, spiral bound – 000002

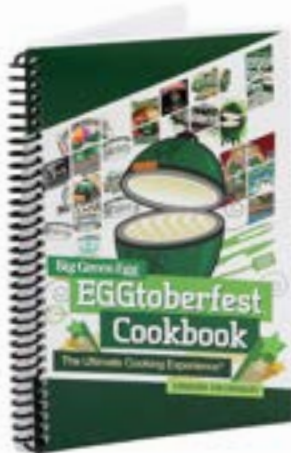

Big Green Egg Tailgate Chair

Relax by your EGG, tailgate in style or enjoy your favorite outdoor sporting event in this super comfortable and durable recreational chair with the official Big Green Egg logo and colors! – 117410



**Mr. EGGhead®
Custom Inflatable**

Turn any Big Green Egg event into a celebration by adding the light-hearted personality of Mr. EGGhead! Sure to produce smiles, this 5 ft (1.5m) character is the perfect host for indoor and outdoor fun, from tailgate parties and community events to an EGGfest® or gathering of friends at your backyard barbecue! The inflatable features an internally-mounted blower for quiet operation; operates on standard 120v household current (US) – 117038

Also available in larger sizes:
12 ft (3.7 m) – 117021
20 ft (6 m) – 117014



BARBECUE SAUCE AND SEASONING

Introducing the NEW line of Big Green Egg Seasonings!

Add flavor to any dish by sprinkling Big Green Egg Seasonings on any of your favorite foods before cooking. For a bolder taste, use the seasonings as a dry rub and apply 30 minutes or longer before cooking, or add them as an ingredient in your favorite recipes.

Gluten-free • No MSG • Kosher

Ancho Chile & Coffee

A robust blend of poblano peppers, coffee and spices
5.5 oz (155 g) – 120557

Citrus & Dill

A tropical blend of citrus, herbs and spices
4.0 oz (113 g) – 120564



Savory Pecan

A nutty blend of sweet and savory flavors
5.3 oz (150 g) – 120571

Sweet & Smoky

Traditional smoked paprika barbecue flavor
5.8 oz (164 g) – 120540



Big Green Egg Barbecue Sauce

Big Green Egg Authentic Smokehouse-Style Barbecue Sauces will enhance the flavor of any barbecue recipe! Four delicious flavors. Convenient 14 oz / 396 g size!

All Natural • Gluten-free • No MSG

Kansas City Style – Sweet and Smoky – 116529
Carolina Style – Bold and Tangy – 116512
Vidalia Onion Sriracha – 116536
Zesty Mustard Honey – 116505



EGG NEWS

... HERE'S WHAT'S TRENDING AROUND THE WORLD

Big Green Egg – Now Starring on YouTube

The Big Green Egg TV crew has been busy producing exciting videos, including new cooking techniques and easy tips for getting started on the EGG, recipes from Big Green Egg Europe's Flavour Fair, or Barbecue Hall of Fame member Ray Lampe (Dr. BBQ) explaining how to prepare the perfect roast. Learn to bake the perfect pizza or see how Chef Linkie Marais grills delicious lamb kabobs ... it's all just a click away on the Big Green Egg website, or at [YouTube.com/BigGreenEggHQ](https://www.youtube.com/BigGreenEggHQ).



Social Media and the Big Green Egg ... Join the Conversation

You'll find a constant variety of informative and entertaining content at the BigGreenEgg.com website, with recipes, cooking tips, video tutorials, exclusive on-line publications and much more! Our Facebook, Twitter, Pinterest, Instagram and Forum fans (www.EGGheadForum.com) love to share tips and suggestions about cooking on the EGG. The Big Green Egg social network is also a great way to keep up with EGGfests and events in your area.



Authorized Dealers – The Force Behind The Ultimate Cooking EGGsperience®

When you purchase a Big Green Egg, you receive much more than the best outdoor cooker in the world ... you also enjoy the benefit of specialized know-how and customer support that only an Authorized EGG Dealer can provide.

Throughout the world, Big Green Egg Authorized Dealers are local, independent business owners who are trained EGGsperts, ready to assist consumers with superior product knowledge, unmatched customer service, the full line of EGGcessories and warranty support. That's why Big Green Egg does not authorize sales on-line or through discount club or chain stores. Always be sure you are buying genuine Big Green Egg products from an Authorized Dealer ... just click the convenient Dealer Locator button at BigGreenEgg.com to find an Authorized Dealer near you, or visit any of these websites:



Australia	BigGreenEgg.com.au
Canada	BigGreenEgg.ca
Europe	BigGreenEgg.eu
Israel	BigGreenEgg-Israel.com
Mexico	BigGreenEgg.com.mx
New Zealand	BigGreenEgg.co.nz
South Africa	BigGreenEgg.co.za
United Kingdom	BigGreenEgg.co.uk

Join Our Winning Team

To accommodate our continued growth, The Big Green Egg Company has opportunities for qualified dealers in many market areas. Find out how you can join the winning Big Green Egg team by scanning the QR Code or emailing your contact information to: become.a.dealer@BigGreenEgg.com – or see the Become a Dealer section at BigGreenEgg.com



BECOME
A DEALER



Have questions? Dr. BBQ has answers!



What makes a Big Green Egg so amazing?



Can I really cook anything in an EGG?



Big Green Egg has a FREE Lifetime warranty! Really!



What size EGG is best for me?



I'm getting hungry - show me some amazing recipes!



What's so good about Big Green Egg Natural Lump Charcoal?



What should I know about EGGcessories?



Why is the EGG an unmatched value?



Why is an EGG a better choice than other grills?



How long has the company been around?



Does an EGG really make better pizza than a brick oven?



Why doesn't the EGG come with a rotisserie device?

SCAN QR CODES WITH YOUR SMART PHONE



Dr. BBQ

Barbecue Competition Grand Champion

Author of NFL Gameday Cookbook, BBQ Road Trip and Ray Lampe's Big Green Egg Cookbook

Inducted into the Barbecue Hall of Fame

Big Green EGGspert!

Big Green Egg®

EXPERIENCE A WORLD OF FLAVOR!

The world's best chefs, and legions of backyard barbecue fans, demand the ultimate equipment to stay on top. And that's why so many accomplished cooks own the Big Green Egg.

Versatility

Grilling, roasting, smoking or baking ... the Big Green Egg stands alone as the most versatile outdoor cooking product on the market today.

A Complete Outdoor Cooking System

With hundreds of EGGcessories designed exclusively for the EGG, the culinary possibilities are endless!

Highest Quality

Our state-of-the-art ceramic technologies and patented components provide the best thermal properties, material quality and cooking performance!

Lasts a Lifetime

The Big Green Egg comes with a Best-In-Class limited lifetime warranty. We have been standing behind our products for over forty years.



DOWNLOAD
MAGAZINE

Big Green Egg LifeStyle is published by The Big Green Egg, Inc. in the United States and other countries. This publication is © copyright by Big Green Egg, Inc., and All Rights Are Reserved Worldwide. For additional copies, please visit your Big Green Egg dealer, or you may view the publication online at BigGreenEgg.com or scan QR Code to view online publication.